

Air cooled liquid chiller with multiscroll technology for outdoor installation

SPINchiller⁴

WSAT-YSC4 265.6 - 350.8



TECHNICAL BULLETIN



SIZE - EXCELLENCE	265.6	290.7	310.7	350.8
COOLING CAPACITY [KW]	720	780	814	939
SIZE - PREMIUM	265.6	290.7	310.7	350.8
COOLING CAPACITY [KW]	720	780	814	939

Pagina

3	Features and benefits
4	Standard unit technical features
7	Unit configuration
8	Built-in options
12	General technical data
20	Prerformance
24	Configurations
29	Accessories - Hydronic assembly
37	Option compatibility
38	Dimensional drawings



Clivet participates in the ECP Programme for “Liquid Chillers and Hydronic Heat Pumps”.
Check ongoing validity of certificate on www.eurovent-certification.com”

Features and benefits

SPINchiller⁴: Modular scroll technology for every application

SPINchiller⁴ is the new generation of Clivet liquid chillers and heat pump with modular scroll technology. Thanks to its high seasonal efficiency and the adoption of the R-32 refrigerant with reduced environmental impact, it represents the ideal solution for different types of installation.

WSAT-YSC4 265.6 ÷ 350.8

Air cooled liquid chiller with multiscroll technology

- Range 720 ÷ 939 kW
- EXCELLENCE / PREMIUM Version
- Seasonal efficiency (SEER) 5,25 / 5,00
- Operating with 50°C outdoor air temperature
- Operating with -18°C outdoor air temperature
- Full aluminium microchannel coils
- Partial recovery of the condensing heat
- Plate exchangers / shell and tube
- 2 refrigeration circuits



WSAT-YSC4 80.3 ÷ 240.6

Air cooled liquid chiller with multiscroll technology

- Range 222 ÷ 675 kW
- EXCELLENCE / PREMIUM Version
- Seasonal efficiency (SEER) 4,9 / 4,6
- Operating with 50°C of outdoor air temperature
- Operating with -18°C of outdoor air temperature
- Full aluminium microchannel coils
- Partial recovery of the condensing heat
- Total recovery of the condensing heat
- Plate exchangers / shell and tube
- 2 refrigeration circuits



WSAN-YSC4 80.3 ÷ 240.6

Air cooled heat pump with multiscroll technology

- Range Range 215 - 655 kW
- EXCELLENCE / PREMIUM Version
- Seasonal efficiency (SEER) 4,8 / 4,5
- Operating with 48°C of outdoor air temperature in cooling
- Operating with -15°C of outdoor air temperature in heating
- Copper/aluminum condensing coil
- Partial recovery of the condensing heat
- Plate exchangers / shell and tube
- 2 refrigeration circuits



WSAN-YSC4 260.8 ÷ 480.12

Air cooled heat pump with multiscroll technology

- Range 670 - 1260 kW
- EXCELLENCE / PREMIUM Version
- Seasonal efficiency (SEER) 4,8 / 4,6
- Operating with 48°C of outdoor air temperature in cooling
- Operating with -15°C of outdoor air temperature in heating
- Copper/aluminum condensing coil
- Partial recovery of the condensing heat
- Plate exchangers / shell and tube
- 4 refrigeration circuits

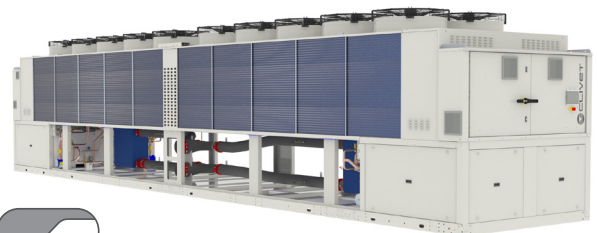

Compressor

High efficiency hermetic orbiting scroll compressor complete with oil charge, motor over-temperature and over-current devices and protection against excessive gas discharge temperature with oil heater, which starts automatically, keeps the oil from being diluted by the refrigerant when the compressor stops. Compressors, fitted on rubber antivibration mounts to prevent transmission of noise and vibration, are connected in TRIO or POKER on a single refrigerating circuit with biphasic oil equalisation, it allows to reach high efficiency at partial load. Uniform compression process with reduced number of moving parts which ensure very low levels of noise and vibration.

Structure

Structure and base made entirely of sturdy sheet steel, thickness of 30/10 or 40/10, with the surface treatment in Zinc–Magnesium painted, for the parts in view, with polyester powder RAL 9001 that guarantees excellent mechanical characteristics and high corrosion strength over time.

Internal exchanger (evaporator)

Direct expansion heat exchanger, braze-welded AISI 316 stainless steel plates, in pack without seals using copper as the brazing material, with low refrigerant charge and large exchange surface, complete with:

- external thermal insulation no-condensation, thickness 9,5 mm, in extruded elastomer foam with closed cells;
- differential pressure switch, water side;
- antifreeze heater to protect the water side exchanger, preventing the formation of frost if the water temperature falls below a set value.

Maximum operating pressure exchanger: 10 bar on the water side

External exchanger (condenser)

Full aluminium microchannel coil with V structure open angle geometry. The entire exchanger (tubes, fins and manifolds) is made of aluminium and welded into a single body through a special brazing technology in a controlled-temperature chamber. The fins have a special corrugated surface to ensure maximum heat exchange efficiency. The special flat configuration of the pipes reduces the section that opposes to the air flow, limiting the pressure drops and maximizing the surface. The total refrigerant charge into the microchannel coil is reduced by 30% compared to an equivalent copper coil.

Fan

Axial fans with high performance and low-noise, balanced statically and dynamically, with blades in aluminum sheet coated in PP and sickle profile terminating with "Winglets", Wall ring in sheet steel pre-galvanised, directly coupled to the three-phase electric motor with external rotor and IP54 protection and class F insulation. Fans are located in aerodynamically shaped structures, equipped with accident prevention steel guards.

EXCELLENCE Version supplied with variable speed control fans (ECOBREEZE).

PREMIUM Version supplied with variable speed control fans (Phase - cutting)

Refrigeration circuit

Two independent refrigeration circuits made of copper, brazed and factory-assembled, complete with:

- anti-acid dehydrator filter with solid cartridge complete with quick-fit connector for refrigerant;
- safety high pressure switch,
- high and low pressure transducer;
- refrigerant temperature probe;
- electronic expansion valve;
- high pressure safety valve (safety valve with sealed tap open for inspection);
- low pressure safety valve (safety valve with sealed tap open for inspection);
- liquid flow and humidity indicator;
- cut-off valve on liquid line

Suction pipes thermally insulated with highly flexible EPDM rubber closed-cell elastomer insulation. Each cooling circuit is tested under pressure for leaks and is supplied complete with load of refrigerant gas.

Electrical panel

Entirely manufactured and wired in conformity to the EN 60204 standard. The power section includes:

- door locking main circuit breaker;
- main power supply terminals (400V / 3Ph / 50Hz)
- magneto-thermal cut-out switches to protect compressors;
- magneto-thermal cut-out switches to protect fans;
- compressor control contactor

The control section includes:

- proportional-integral-derivative adjustment of water temperature;
- anti-freeze protection;
- management of unit start-up from local or remote device (serial);
- compressor timing and protection;
- potential-free contacts for compressor status;
- self-diagnosis system with immediate display of the failure code;
- pre-alarm function for water anti-frost and refrigerant gas high pressure functions;
- visualisation of no. of hours of compressor operation;
- interface terminal with graphic display;
- multifunction phase monitor;
- remote ON/OFF control;
- second set-point enabling by potential-free contact;
- automatic rotation control of compressor start-up to balance wear (breakaway + hours of operation);
- relay for remote cumulative fault signal;
- set values, error codes and parameters can be displayed;
- set-point compensation with outdoor air temperature probe
- electrical socket (max 400W)

Standard unit technical features

Accessories

- E-coated microchannel coil
- Finned coil protection grilles and compressor compartment (available only with options: PPBM)
- Energy meter
- Demand limit with signal 4-20mA
- Demand limit with signal 0-10V
- Set point compensation with 4-20 mA signal
- Set-point compensation with 0-10 V signal
- Serial communication module for Modbus supervisor
- Serial communication module to LonWorks supervisor
- Serial communication module for BACnet/IP supervisor
- Inverter driven variable flow-rate user side control depending on the temperature differential
- Variable flow-rate control of the inverter pump external to the unit depending on the temperature differential
- Refrigerant leak detector assembled on the casing (available only with SC and EN configuration)
- Remote control via microprocessor control (separately supplied accessories)
- Electrical panel antifreeze protection for min. outdoor temperature down to -25°C
- Electrical panel antifreeze protection for min. outdoor temperature down to -39°C
- Spring antivibration mounts (separately supplied accessories)
- Anti-seismic spring antivibration mounts (separately supplied accessories)
- Couple of manually operated shut-off valves (separately supplied accessories)
- Steel mesh strainer on the water side (separately supplied accessories)
- Mains power supply (separately supplied accessories)
- Microchannel coils protection panels
- Ecoshare function for the automatic management of a group of units
- Power factor correction capacitors
- Disposal for inrush current reduction
- Storage tank
- Cutoff valve on compressor supply and return
- Switching valve with dual safety valves
- Soundproofing paneling of the pumping unit
- Differential pressure switch water side with antifreeze protection

Test

Unit subjected to factory-tested in specific steps and test pressure of the piping of the refrigerant circuit (with nitrogen and hydrogen), before shipping them.

Unit equipment with outdoor air low temperatures

MINIMUM OUTDOOR AIR TEMPERATURE		OPERATING UNIT	UNIT IN STAND-BY (5) (fed unit)	UNIT IN STORAGE (unit not fed)
+11°C	1	✓ STANDARD UNIT	✓ STANDARD UNIT	
+2°C	2			
-5°C	3			
Between -10°C and -15°C	4	✓ STANDARD UNIT ✓ GLYCOL IN AN APPROPRIATE PERCENTAGE o WATER SIDE DIFFERENTIAL PRESSURE SWITCH WITH ANTI-FREEZE PROTECTION (PSWSA)	✓ STANDARD UNIT ✓ GLYCOL IN AN APPROPRIATE PERCENTAGE o WATER SIDE DIFFERENTIAL PRESSURE SWITCH WITH ANTI-FREEZE PROTECTION (PSWSA)	✓ STANDARD UNIT ⁽⁶⁾
Between -15°C and -18°C		✓ STANDARD UNIT ✓ GLYCOL IN AN APPROPRIATE PERCENTAGE ✓ ELECTRICAL PANEL ANTIFREEZE PROTECTION (RE-25)	✓ WATER EMPTY UNIT or GLYCOL IN AN APPROPRIATE PERCENTAGE ✓ ELECTRICAL PANEL ANTIFREEZE PROTECTION (RE-25) X NOT SUITABLE: BUILT-IN PUMPS, PARTIAL RECOVERY, STORAGE TANK, SHELL AND TUBE EXCHANGER	NOT POSSIBLE
Between -18°C and -25°C		NOT POSSIBLE		
Between -25°C and -39°C		NOT POSSIBLE	✓ WATER EMPTY UNIT or GLYCOL IN AN APPROPRIATE PERCENTAGE ✓ ELECTRICAL PANEL ANTIFREEZE PROTECTION (RE-39) ✓ ACOUSTIC CONFIGURATION SC or EN ✓ WATER SIDE DIFFERENTIAL PRESSURE SWITCH WITH ANTI-FREEZE PROTECTION (PSWSA) X NOT SUITABLE: BUILT-IN PUMPS, PARTIAL RECOVERY, STORAGE TANK, SHELL AND TUBE EXCHANGER	NOT POSSIBLE

Data referred to the following conditions:
 - internal exchanger water = 12/7°C

1. Part load unit and air speed equal to 1 m/s.
2. Part load unit and air speed equal to 0.5 m/s.
3. Part load unit and outdoor air temperature at rest.
4. Unit at full load and outdoor air temperature at rest.

⁽⁵⁾ The water pumping unit must be fed and connected to the unit according to the manual.

⁽⁶⁾ Unit without water or containing water with an appropriate quantity of glycol.

At the unit start-up the water temperature or water with glycol must be inside the operating range indicated in the "Operating range" graph. To know the water freezing temperature on varying the glycol percentage refer to the specific 'Correction factors for glycol use' table.

⚠ Air conditions which are at rest are defined as the absence of air flowing towards the unit. Weak winds can induce air to flow through the exchanger and air-levels which can cause a reduction in the operating range. In the presence of predominant winds it is necessary to use suitable windbreak barriers.

Unit configuration

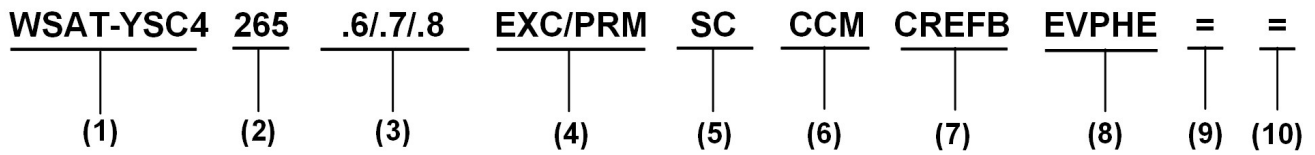

(1) Range

WSAT = Air-cooled liquid chiller

YSC4 = SPINchiller range with multiscroll compressors and R-32 refrigerant

(2) Size

265 = Nominal compressor capacity (HP)

(3) Compressors

.6 / .7 / .8 = Compressor quantity

(4) Energy version

EXC = EXCELLENCE Version (Standard)

PRM = PREMIUM Version

(5) Acoustic configuration

ST = Standard acoustic configuration

SC = Acoustic configuration with compressor soundproofing (standard)

EN = Super-silenced acoustic configuration

(6) Condensing coil

CCM = Aluminum microchannel condensing coils (Standard)

CCME = E-coated microchannel coil

(7) Fans

CREFB = Device for fan consumption reduction of the external section ECOBREEZE type (Standard for EXC version)

CREFP = Device for fan consumption reduction of external section at variable speed (Phase-cutting) (Standard for PRM version).

(8) Evaporator

EVPHE = Plate exchangers (Standard)

EVFTP = Shell and tube evaporator PED test

(9) Condensation heat recovery

(-) not required (standard)

D = Partial energy recovery

(10) Pumping unit

(-) not required (standard)

2PM = Hydropack with N° 2 pumps

2PMV = Hydropack with N° 2 inverter pumps

1P1SB = Hydropack with n°1 pump + n°1 in stand-by

1P1SBV = Hydropack with one inverter pump and one standby pump with dedicated inverter

IVFDT

Inverter driven variable flow-rate user side control depending on the temperature differential

This option allows water flow-rate modulation to the unit during partial load conditions, maintaining stable the temperature difference between inlet and outlet to the heat exchanger. Flow-rate modulation is managed by embedded logic thanks to built-in temperature probes.

Designed for systems with primary circuit variable flow-rate systems decoupled from secondary circuit. With no building load the unit switches off the compressors while concerning pumps is possible to select:

- Active pumps with minimum flow-rate, monitoring secondary circuit temperature variations
- Pump switching off, periodically activating them (settable time) leading secondary circuit temperatures on primary circuit
- Pump switching off and waiting for the user signal for activation (free potential)

⚠ Device suitable for hydronic assemblies installed on board.

IVFEDT

Variable flow-rate control of the inverter pump external to the unit depending on the temperature differential

This option allows water flow-rate modulation to the of pumping groups installed by the customer (external to the unit) during partial load conditions, maintaining stable the temperature difference between inlet and outlet to the heat exchanger. Flow-rate modulation is managed by embedded logic thanks to built-in temperature probes.

⚠ Device for hydronic assemblies not installed on board.

ACC

Storage tank

Steel storage tank complete with double layer covering with closed-cell insulation, stainless steel anti-freeze immersion resistance, bleed valve, draw off cock, cast-iron shut-off butterfly valve with quick connections and activation lever with a mechanical calibration lock at the evaporator output, quick connections with insulated casing.

For size 265.6, 290.7 and 310.7 the storage tank capacity is 750 liters.

For size 350.8 the storage tank capacity is 1050 liters.

⚠ The device is installed and wired built-in the unit and is placed on the return from the system.

CONTA2

Energy meter

Allows to display and record the unit's main electrical parameters. The data can be displayed with the user interface on the unit or via the supervisor through the specific protocol variables.

It is possible to control: voltage (V), absorbed current (A), frequency (Hz), cosfi, power input (kW), absorbed energy (kWh), harmonic components (%)

The device is installed and wired on the unit.

CMSC9

Serial communication module for Modbus supervisor

This enables the serial connection of the supervision system, using Modbus as the communication protocol. It enables access to the complete list of operational variables, commands and alarms. Using this accessory every unit can dialogue with the main supervision systems.

The device is installed and wired on the unit.

⚠ The total length of each individual serial line must not exceed 1000 m and the line must be connected in bus type (input/output).

CMSC10

Serial communication module to LonWorks supervisor

This enables the serial connection of the supervision system which uses the LonWorks communication protocol. It enables access to a list of operating variables, commands and alarms which comply with the Echelon® standard.

The device is installed and wired on the unit.

⚠ The configuration and management activities for the LonWorks networks are the responsibility of the client.

⚠ LonWorks technology uses the LonTalk® protocol for communicating between the network nodes. Contact the service supplier for further information.

⚠ The total length of each serial line do not exceed 1000 meters and the line must be connected in bus typology (in/out)

CMSC11

Serial communication module for BACnet/IP supervisor

This enables the serial connection of the supervision system, using BACnet as the communication protocol. It enables access to the complete list of operational variables, commands and alarms. Using this accessory every unit can dialogue with the main supervision systems.

The device is installed and wired on the unit.

⚠ Le attività di configurazione e conduzione della rete BACnet sono a carico del Cliente

⚠ The total length of each individual serial line must not exceed 1000 m and the line must be connected in bus type (input/output).

Built-in options

SCP4	Set-point compensation with 0-10 V signal <p>This device enables the set-point to be varied which is pre-set using an external 0-10 V signal. The device is installed and wired built-in the unit.</p>
SPC1	Set point compensation with 4-20 mA signal <p>This device enables the set-point to be varied which is pre-set using an external 4-20 mA signal. The device is installed and wired on the unit.</p>
DLM0-10	Demand limit with signal 0-10V <p>The device allows to limit the absorption unit through an external signal type 0-10V.</p>
DLM4-20	Demand limit with signal 4-20mA <p>The device allows to limit the absorption unit through an external signal type 4-20mA.</p>
ECS	ECOSHARE function for the automatic management of a group of units <p>The device allows automatic management of units that operate on the same hydraulic circuit, by creating a local communication network.</p> <p>The device allows rotation based on the criterion of minimum wear and management of stand-by units. The Ecoshare network coordinates the system's thermoregulation so that all the Slaves receive from the Master the on/off status control and the offset to reduce the setpoint values of the individual Slaves (which will operate with their temperature controller), according to wear, sleep function status in progress and the presence of alarms that would prevent activation of the individual Slave.</p> <p>There are various unit sizes. Every unit must have the ECOSHARE mode. The group control is by a Master unit. The local network can be extended up to 7 units (1 Master and 6 Slave).</p> <p>For units in ECOSHARE, the minimum water content of the system is equal to that of the largest unit increased by +25% for each additional unit connected.</p> <p>⚠ The unit supplied with this device can also be equipped at the same time with the RCMRX option and one of the CMSC9 / CMSC10 / CMSC11 options. ⚠ It is necessary to provide a non-return valve for each unit installed in hydraulic parallel and equipped with an hydronic assembly installed on board (Installation by the Customer).</p>
PFCC	Power-factor correction capacitors (cosφ > 0.95) <p>The component is necessary to lower the phase difference between current and voltage in the electromagnetic components of the unit (e.g. asynchronous motors). The component allows to put the cosφ power factor to values on average higher than 0.95, reducing the network reactive power. This often leads to an economic benefit which the energy provider grants to the final user.</p> <p>The device is installed and wired on the unit.</p>
SFSTR	Disposal for inrush current reduction <p>Electronic device which automatically starts up the compressors gradually, reducing the starting current for the unit by around 40% in comparison with the nominal value. This results in the reduction of the starting torque of the ON/OFF compressor, it is more protected from mechanical stresses leading to an increased life of the component. The noise is also reduced.</p> <p>The device is installed and wired on the unit.</p>
RE-25	Electrical panel antifreeze protection for min. outdoor temperature down to -25°C <p>This option is necessary for very cold climates, where the external temperature can go down to -25°C. It includes self-regulating temperature maintaining resistances which are able to protect the electrical panel against condensation and frost guaranteeing that it functions correctly. The choice of device should be carried out on the basis of the minimum temperatures reached at the unit installation site.</p> <p>The device is installed and wired on the unit.</p> <p>⚠ This accessory does not lead to substantial variations in the electrical data for the unit which has been declared in the Electrical Data section. ⚠ This accessory operates even when the unit is switched off provided that the power supply is maintained active and the unit continues to be connected. ⚠ It is necessary to make precautions against build up of snow and ice in front of the exhaust and outdoor air inlet locations</p>
RE-39	Electrical panel antifreeze protection for min. outdoor temperature down to -39°C <p>This option is necessary for very cold climates, where the external temperature can go down to -39°C. It includes self-regulating temperature maintaining resistances which are able to protect the electrical panel against condensation and frost guaranteeing that it functions correctly, and self-regulating resistances for the protection of the high-pressure safety switches.</p> <p>The choice of device should be carried out on the basis of the minimum temperatures reached at the unit installation site. The device is installed and wired on the unit.</p> <p>⚠ This accessory does not lead to substantial variations in the electrical data for the unit which has been declared in the Electrical Data section. ⚠ This accessory operates even when the unit is switched off provided that the power supply is maintained active and the unit continues to be connected. ⚠ It is necessary to make precautions against build up of snow and ice in front of the exhaust and outdoor air inlet locations</p>

PSWSA	<p>Differential pressure switch water side with antifreeze protection</p> <p>It allows unit operation with -15°C of outdoor air temperature without using glycol. It includes a heating cable able to protect the water side differential pressure switch. The device is installed and wired built-in the unit.</p>	
SDV	<p>Cutoff valve on compressor supply and return</p> <p>An option which integrates the supply cutoff valve, which is supplied as standard. The presence of the cock at the intake as well enables the compressors to be isolated and substituted without discharging the refrigerant from within the refrigeration circuit. This means that the extraordinary maintenance activities are facilitated. Device installed built-in the unit.</p>	
RDVS	<p>Switching valve with dual safety valves</p> <p>Allows maintenance or replacement of the safety valve without draining the unit. Two pressure relief valves (each valve is sized according to 13136 clause 6.2) connected via a changeover valve are provided.</p>	
CCME	<p>E-coated microchannel coil</p> <p>The full aluminium microchannel coil is completely treated by electrolysis so as to create a protective layer of epoxy polymer on the surface, with the following characteristics:</p> <ul style="list-style-type: none"> • over 3000 hours of protection against salt spray (ASTM G85 A3 - SWAAT); • over 2000 hours of protection against UV rays (ASTM G155-05a) <p>provide a very high resistance against corrosion.</p>	
RPRI	<p>Refrigerant leak detector assembled on the casing</p> <p>Leak detector device built-in installed and placed inside the compressor box, it detects leaks of the internal refrigeration circuit.</p> <p>⚠ Option available only for acoustic configuration with compressor soundproofing (SC) and super-silenced (EN).</p>	
PPBM	<p>Microchannel coils protection panels</p> <p>Microchannel coils protection panels supplied on the manifold side. They guarantee greater protection during transport and from accidental contact with things or people.</p>	
PGCC	<p>Finned coil protection grilles and compressor compartment</p> <p>This accessory is used to protect the external coil from the accidental contact with external things or people. Ideal for installation in places where persons can pass from, such as car parks, terraces, etc. The device is installed and wired on the unit. Grille slot 25 mm.</p> <p>⚠ This option is not suitable for application in sulphuric environments</p> <p>⚠ Option available only in combination with microchannel coils protection panels (PPBM)</p>	
EVFTP	<p>Shell and tube evaporator PED test</p> <p>Direct expansion exchanger with refrigerant side independent circuit for each compressor. The exchanger is composed of a cover made of carbon steel. The tubes, anchored to the tube plate by mechanical expansion, are made of copper, high efficiency, internally rifled to improve thermal exchange and specially designed for use with modern ecological refrigerants. It also includes a water side protection differential switch, an anti-freeze heating element to protect against icing, and covering in closed-cell thermo-insulating material that prevents the formation of condensation and heat exchange with the exterior. The water connections of the exchanger are quick-release with splined joint (Victaulic).</p>	
PFGP	<p>Soundproofing paneling of the pumping unit</p> <p>Configuration used to increase the hydronic assembly's silent operation. It is made up of steel casings lined internally with high-density material with a soundproofing function. The casings are pre-painted with RAL 9001 color. Option available for all pumping groups installed on the unit, in combination with the standard acoustic configuration (ST) and with compressor soundproofing (SC).</p>	

Built-in options

RCMRX Remote control via microprocessor control

This option allows to have full control over all the unit functions from a remote position. It can be easily installed on the wall and has the same aspect and functions of the user interface on the unit.

- ⚠ All device functions can be repeated with a normal portable PC connected to the unit with an Ethernet cable and equipped with an internet navigation browser.
- ⚠ The device must be installed on the wall with suitable plugs and connected to the unit (installation and wiring to be conducted by the Customer). Maximum remote control distance 350 m without auxiliary power supply.
- ⚠ For distances greater than 350 m and in any case less than 700 m it is necessary to install the 'PSX - Mains power unit' accessory.
- ⚠ Data and power supply serial connection cable n.1 twisted and shielded pair. Diameter of the individual conductor 0.8 mm.
- ⚠ Installation is a responsibility of the Customer.

AMMX Spring antivibration mounts

The spring antivibration mounts are attached in special housing on the support frame and serve to smooth the vibrations produced by the unit thus reducing the noise transmitted to the support structure.

- ⚠ Installation provided by the Customer.

AMMSX Anti-seismic spring antivibration mounts

The anti-seismic spring antivibration mounts must be fastened in special housings on the supporting metal struts. The containment structure is designed to ensure high resistance multidirectional forces acting on the surface of the unit in the presence of wind and / or telluric movements. The antivibration mounts have been tested according to ANSI/ASHRAE 171-2008 standard (Method of Testing Seismic Restraint devices for HVAC&R Equipment). The performance levels and the test methodology have been validated and certified by Lloyd's Register.

- ⚠ Installation provided by the Customer.

IFWX Steel mesh strainer on the water side

The device stops the exchanger from being clogged by any impurities which are in the hydraulic circuit. The mechanical steel mesh strainer must be placed on the water input line. It can be easily dismantled for periodical maintenance and cleaning. It also includes:

- cast-iron shut-off butterfly valve with quick connections and activation lever with a mechanical calibration lock;
- quick connections with insulated casing.

- ⚠ Pressure drop referred to a clean filter.
- ⚠ Installation is the responsibility of the Client, externally to the unit.
- ⚠ Check for the presence of the required hydraulic shut-off valves in the system, in order to undertake periodical maintenance.

Steel mesh filter pressure drop

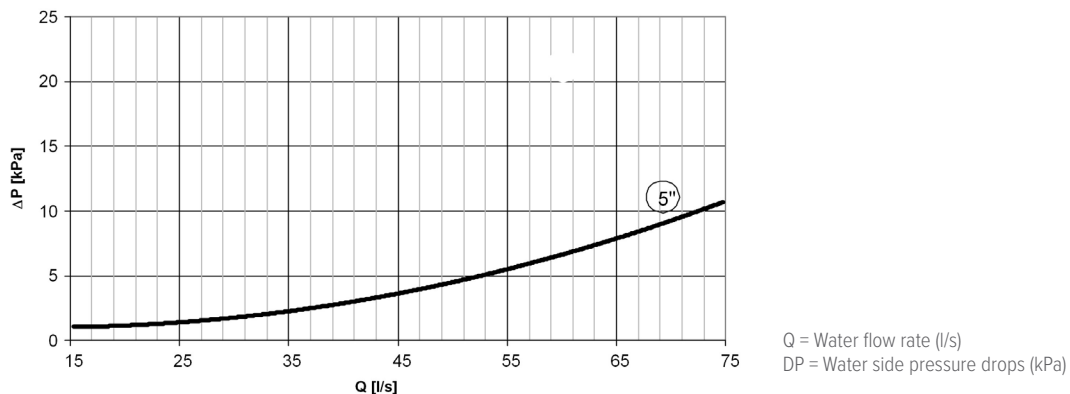

CSVX Couple of manually operated shut-off valves

The kit allows to isolated the input and output water circuit. It includes:

- no. 2 of cast-iron shut-off butterfly valves with fast fittings and activation lever with a mechanical setting lock
- no. 2 of victaulic connections

- ⚠ Installation is the responsibility of the Client, externally to the unit.

PSX Mains power supply

The device makes communication between the unit and the remote controller possible with user interface even when the serial line is longer than 350 m. It should be connected to the serial line 350 m away from the unit and can be extended up to a maximum total of 700 m. The device requires an external 230V AC power supply.

- ⚠ Power supply at 230V AC provided by Customer.
- ⚠ Installation is a responsibility of the Customer.

Performance - Excellence

Standard acoustic configuration (ST) / Compressor soundproofing (SC)

Size			265.6	290.7	310.7	350.8
Cooling capacity	1	[kW]	720	780	815	940
Compressor power input	1	[kW]	220	246	265	297
Total power input	2	[kW]	231	257	277	311
Partial recovery heating capacity	3	[kW]	248	270	284	326
EER	1	-	3,12	3,03	2,94	3,02
Water flow-rate (User Side)	1	[l/s]	34,2	37,0	38,7	44,6
Internal exchanger pressure drop	1	[kPa]	23,2	27,1	29,5	32,9
Cooling capacity (EN14511:2018)	4	[kW]	720	780	814	939
Total power input (EN14511:2018)	4	[kW]	232	259	279	314
EER (EN14511:2018)	4	-	3,10	3,01	2,92	3,00
SEER	6	-	5,28	5,26	5,23	5,22
SEPR	7	-	6,54	6,48	6,42	6,40
Cooling capacity (AHRI 550/590)	5	[kW]	714	774	809	933
Compressor power input (AHRI 550/590)	5	[kW]	230	256	276	310
COPR	5	-	3,11	3,02	2,93	3,01
IPLV	5	-	6,04	6,00	5,93	5,92

The Product is compliant with the Erp (Energy Related Products) European Directive. It includes the Commission delegated Regulation (EU) No 2016/2281, also known as Ecodesign Lot21. Contains fluorinated greenhouse gases (GWP 675)

1. Data referred to the following conditions: internal exchanger water temperature = 12/7 °C. Entering external exchanger air temperature = 35°C. Evaporator fouling factor = 0.44 x 10⁻⁴ m² K/W
2. The Total Power Input value does not take into account the part related to the pumps and required to overcome the pressure drops for the circulation of the solution inside the exchangers
3. Recovery exchanger water = 40/45°C
4. Data compliant to Standard EN 14511:2018 referred to the following conditions: internal exchanger water temperature = 12/7 °C. Entering external exchanger air temperature = 35°C
5. Data compliant to Standard AHRI 550/590 referred to the following conditions: internal exchanger water temperature = 6,7 °C. Water flow-rate 0,043 l/s per kW. Entering external exchanger air temperature = 35°C. Evaporator fouling factor = 0.18 x 10⁻⁴ m² K/W
6. Data calculated in compliance with EN 14825:2018.
7. Data calculated according to the EU 2016/2281 Regulation

Super-silenced acoustic configuration (EN)

Size			265.6	290.7	310.7	350.8
Cooling capacity	1	[kW]	700	755	790	915
Compressor power input	1	[kW]	230	258	278	314
Total power input	2	[kW]	238	265	285	322
Partial recovery heating capacity	3	[kW]	244	266	280	322
EER	1	-	2,94	2,85	2,77	2,84
Water flow-rate (User Side)	1	[l/s]	33,2	35,9	37,5	43,5
Internal exchanger pressure drop	1	[kPa]	22,0	25,5	27,8	31,2
Cooling capacity (EN14511:2018)	4	[kW]	700	755	790	914
Total power input (EN14511:2018)	4	[kW]	239	266	287	324
EER (EN14511:2018)	4	-	2,92	2,83	2,75	2,82
SEER	6	-	5,22	5,26	5,2	5,21
SEPR	7	-	6,47	6,50	6,33	6,38
Cooling capacity (AHRI 550/590)	5	[kW]	695	750	784	908
Compressor power input (AHRI 550/590)	5	[kW]	237	264	284	321
COPR	5	-	2,93	2,84	2,76	2,83
IPLV	5	-	5,97	6,00	5,85	5,88

The Product is compliant with the Erp (Energy Related Products) European Directive. It includes the Commission delegated Regulation (EU) No 2016/2281, also known as Ecodesign Lot21. Contains fluorinated greenhouse gases (GWP 675)

1. Data referred to the following conditions: internal exchanger water temperature = 12/7 °C. Entering external exchanger air temperature = 35°C. Evaporator fouling factor = 0.44 x 10⁻⁴ m² K/W
2. The Total Power Input value does not take into account the part related to the pumps and required to overcome the pressure drops for the circulation of the solution inside the exchangers
3. Recovery exchanger water = 40/45°C
4. Data compliant to Standard EN 14511:2018 referred to the following conditions: internal exchanger water temperature = 12/7 °C. Entering external exchanger air temperature = 35°C
5. Data compliant to Standard AHRI 550/590 referred to the following conditions: internal exchanger water temperature = 6,7 °C. Water flow-rate 0,043 l/s per kW. Entering external exchanger air temperature = 35°C. Evaporator fouling factor = 0.18 x 10⁻⁴ m² K/W
6. Data calculated in compliance with EN 14825:2018.
7. Data calculated according to the EU 2016/2281 Regulation

General technical data

Performances - Premium

Standard acoustic configuration (ST) / Compressor soundproofing (SC)

Size			265.6	290.7	310.7	350.8
Cooling capacity	1	[kW]	720	780	815	940
Compressor power input	1	[kW]	220	246	265	297
Total power input	2	[kW]	231	257	277	311
Partial recovery heating capacity	3	[kW]	248	270	284	326
EER	1	-	3,12	3,03	2,94	3,02
Water flow-rate (User Side)	1	[l/s]	34,2	37,0	38,7	44,6
Internal exchanger pressure drop	1	[kPa]	23,2	27,1	29,5	32,9
Cooling capacity (EN14511:2018)	4	[kW]	720	780	814	939
Total power input (EN14511:2018)	4	[kW]	232	259	279	314
EER (EN14511:2018)	4	-	3,10	3,01	2,92	3,00
SEER	6	-	5,03	5,01	4,98	4,94
SEPR	7	-	6,19	6,19	6,13	6,08
Cooling capacity (AHRI 550/590)	5	[kW]	714	774	809	933
Compressor power input (AHRI 550/590)	5	[kW]	230	256	276	310
COPR	5	-	3,11	3,02	2,93	3,01
IPLV	5	-	5,72	5,72	5,67	5,63

The Product is compliant with the Erp (Energy Related Products) European Directive. It includes the Commission delegated Regulation (EU) No 2016/2281, also known as Ecodesign Lot21. Contains fluorinated greenhouse gases (GWP 675)

1. Data referred to the following conditions: internal exchanger water temperature = 12/7 °C. Entering external exchanger air temperature = 35°C. Evaporator fouling factor = 0.44 x 10⁻⁴ m² K/W
2. The Total Power Input value does not take into account the part related to the pumps and required to overcome the pressure drops for the circulation of the solution inside the exchangers
3. Recovery exchanger water = 40/45°C
4. Data compliant to Standard EN 14511:2018 referred to the following conditions: internal exchanger water temperature = 12/7 °C. Entering external exchanger air temperature = 35°C
5. Data compliant to Standard AHRI 550/590 referred to the following conditions: internal exchanger water temperature = 6,7 °C. Water flow-rate 0,043 l/s per kW. Entering external exchanger air temperature = 35°C. Evaporator fouling factor = 0.18 x 10⁻⁴ m² K/W
6. Data calculated in compliance with EN 14825:2018.
7. Data calculated according to the EU 2016/2281 Regulation

Super-silenced acoustic configuration (EN)

Size			265.6	290.7	310.7	350.8
Cooling capacity	1	[kW]	700	755	790	915
Compressor power input	1	[kW]	231	260	280	316
Total power input	2	[kW]	243	271	291	329
Partial recovery heating capacity	3	[kW]	245	267	282	324
EER	1	-	2,88	2,79	2,71	2,78
Water flow-rate (User Side)	1	[l/s]	33,2	35,9	37,5	43,5
Internal exchanger pressure drop	1	[kPa]	22,0	25,5	27,8	31,2
Cooling capacity (EN14511:2018)	4	[kW]	700	755	790	914
Total power input (EN14511:2018)	4	[kW]	244	273	293	331
EER (EN14511:2018)	4	-	2,86	2,77	2,70	2,76
SEER	6	-	4,87	4,87	4,84	4,83
SEPR	7	-	6,00	6,00	5,93	5,91
Cooling capacity (AHRI 550/590)	5	[kW]	695	749	784	908
Compressor power input (AHRI 550/590)	5	[kW]	242	270	290	328
COPR	5	-	2,87	2,78	2,71	2,77
IPLV	5	-	5,54	5,54	5,48	5,46

The Product is compliant with the Erp (Energy Related Products) European Directive. It includes the Commission delegated Regulation (EU) No 2016/2281, also known as Ecodesign Lot21. Contains fluorinated greenhouse gases (GWP 675)

1. Data referred to the following conditions: internal exchanger water temperature = 12/7 °C. Entering external exchanger air temperature = 35°C. Evaporator fouling factor = 0.44 x 10⁻⁴ m² K/W
2. The Total Power Input value does not take into account the part related to the pumps and required to overcome the pressure drops for the circulation of the solution inside the exchangers
3. Recovery exchanger water = 40/45°C
4. Data compliant to Standard EN 14511:2018 referred to the following conditions: internal exchanger water temperature = 12/7 °C. Entering external exchanger air temperature = 35°C
5. Data compliant to Standard AHRI 550/590 referred to the following conditions: internal exchanger water temperature = 6,7 °C. Water flow-rate 0,043 l/s per kW. Entering external exchanger air temperature = 35°C. Evaporator fouling factor = 0.18 x 10⁻⁴ m² K/W
6. Data calculated in compliance with EN 14825:2018.
7. Data calculated according to the EU 2016/2281 Regulation

Construction

Excellence

Size		265.6	290.7	310.7	350.8
Compressor					
Type of compressors	1			SCROLL	
Refrigerant				R-32	
No. of compressors	No.	6	7	7	8
Rated power (C1)	HP	132	116	132	176
Rated power (C2)	HP	132	176	176	176
Std Capacity control steps		6	8	7	8
Oil charge (C1)	l	18	18	18	24
Oil charge (C2)	l	18	24	24	24
Refrigerant charge (C1)	kg	27	27	27	35
Refrigerant charge (C2)	kg	30	33	33	34
Refrigeration circuits	No.	2	2	2	2
Internal exchanger (evaporator)					
Type of internal exchanger	2			PHE	
N. of internal exchanger	No.	1	1	1	1
Water content	l	99	99	99	110
Minimum system water content	l	3909	3795	3733	3499
External exchanger (condenser)					
Type of internal exchanger	3				CCM
Number of coils	No.	10	10	10	12
External Section Fans					
Type of fans	4			AX	
No. of fans	No.	10	10	10	12
Type of motor	5			EC	
Standard airflow (ST/SC)	l/s	56944	56944	56944	68333
Standard airflow (EN)	l/s	47222	47222	47222	56667
Connections					
Water fittings		5"	5"	5"	5"
Power supply					
Standard power supply		400/3~/50	400/3~/50	400/3~/50	400/3~/50
Electrical data					
F.L.A. - Total	A	495,4	544,2	574,2	657,5
F.L.I. - Total	kW	300,8	330,9	348,5	399,1
M.I.C. - Value	6 A	805,6	854,4	884,4	967,7
M.I.C. - with soft start accessory	6 A	656,6	705,4	735,4	818,7

1. SCROLL = SCROLL Compressor
2. PHE = Plate exchanger
3. CCM = Full aluminium microchannel coils
4. AX = Axial fan
5. EC = Asynchronous motor with permanent magnet commuted electronically.
6. M.I.C.=Maximum unit starting current. The M.I.C. value is obtained adding the max. compressor starting current of the highest size to the power input at max. admissible conditions (F.L.A.) of the remaining electric components.

Voltage unbalance between phases: max 2 %

Voltage variation: max +/- 10%

Electrical data refer to standard units; according to the installed accessories, the data can suffer some variations.

General technical data

Construction

Premium

Size		265.6	290.7	310.7	350.8
Compressor					
Type of compressors	1			SCROLL	
Refrigerant				R-32	
No. of compressors	No.	6	7	7	8
Rated power (C1)	HP	132	116	132	176
Rated power (C2)	HP	132	176	176	176
Std Capacity control steps		6	8	7	8
Oil charge (C1)	l	18	18	18	24
Oil charge (C2)	l	18	24	24	24
Refrigerant charge (C1)	kg	27	27	27	35
Refrigerant charge (C2)	kg	30	33	33	34
Refrigeration circuits	No.	2	2	2	2
Internal exchanger (evaporator)					
Type of internal exchanger	2			PHE	
N. of internal exchanger	No.	1	1	1	1
Water content	l	99	99	99	110
Minimum system water content	l	3909	3795	3733	3499
External exchanger (condenser)					
Type of internal exchanger	3			CCM	
Number of coils	No.	10	10	10	12
External Section Fans					
Type of fans	4			AX	
No. of fans	No.	10	10	10	12
Type of motor	5			AC	
Standard airflow (ST/SC)	l/s	56944	56944	56944	68333
Standard airflow (EN)	l/s	47222	47222	47222	56667
Connections					
Water fittings		5"	5"	5"	5"
Power supply					
Standard power supply		400/3~/50	400/3~/50	400/3~/50	400/3~/50
Electrical data					
F.L.A. - Total	A	508,3	557,1	587,1	673,0
F.L.I. - Total	kW	302,1	332,2	349,7	400,6
M.I.C. - Value	6 A	818,5	867,3	897,3	983,2
M.I.C. - with soft start accessory	6 A	669,5	718,3	748,3	834,2

1. SCROLL = SCROLL Compressor
2. PHE = Plate exchanger
3. CCM = Full aluminium microchannel coils
4. AX = Axial fan
5. AC = Asynchronous three-phase external rotor motor
6. M.I.C.=Maximum unit starting current. The M.I.C. value is obtained adding the max. compressor starting current of the highest size to the power input at max. admissible conditions (F.L.A.) of the remaining electric components.

Voltage unbalance between phases: max 2 %

Voltage variation: max +/- 10%

Electrical data refer to standard units; according to the installed accessories, the data can suffer some variations.

Sound levels- Excellence / Premium

Standard acoustic configuration (ST)

SIZE	Sound power level - Octave band (Hz)								Sound pressure level	Sound power level
	63	125	250	500	1000	2000	4000	8000	dB(A)	dB(A)
265.6	89	80	81	92	89	94	85	80	76	97
290.7	89	80	81	92	89	94	85	80	76	97
310.7	89	80	81	93	90	94	85	80	77	98
350.8	90	81	82	93	90	95	86	81	77	98

Acoustic configuration with compressor soundproofing (SC)

SIZE	Sound power level - Octave band (Hz)								Sound pressure level	Sound power level
	63	125	250	500	1000	2000	4000	8000	dB(A)	dB(A)
265.6	89	80	83	91	89	89	80	75	73	94
290.7	89	80	83	92	89	89	80	75	73	94
310.7	89	80	83	92	89	89	80	76	74	95
350.8	90	81	84	93	90	90	81	76	74	95

Super-silenced acoustic configuration (EN)

SIZE	Sound power level - Octave band (Hz)								Sound pressure level	Sound power level
	63	125	250	500	1000	2000	4000	8000	dB(A)	dB(A)
265.6	88	79	80	87	82	85	78	73	69	90
290.7	88	79	80	87	83	85	78	74	69	90
310.7	89	80	81	89	84	86	79	75	70	91
350.8	90	81	81	89	84	86	79	75	70	91

Sound levels refer to full load units, in test nominal conditions. The sound pressure level refers to 1 m. from the standard unit outer surface operating in open field. Measures according to UNI EN ISO 9614-2 regulations, with respect to the EUROVENT 8/1 certification, which provides for a tolerance of 3 dB(A).

Data referred to the following conditions:

- internal exchanger water temperature = 12/7 °C
- Temperature of air entering the external exchanger = 35°C.

General technical data

Operating range - Excellence / Premium (Acoustic configuration ST/SC)

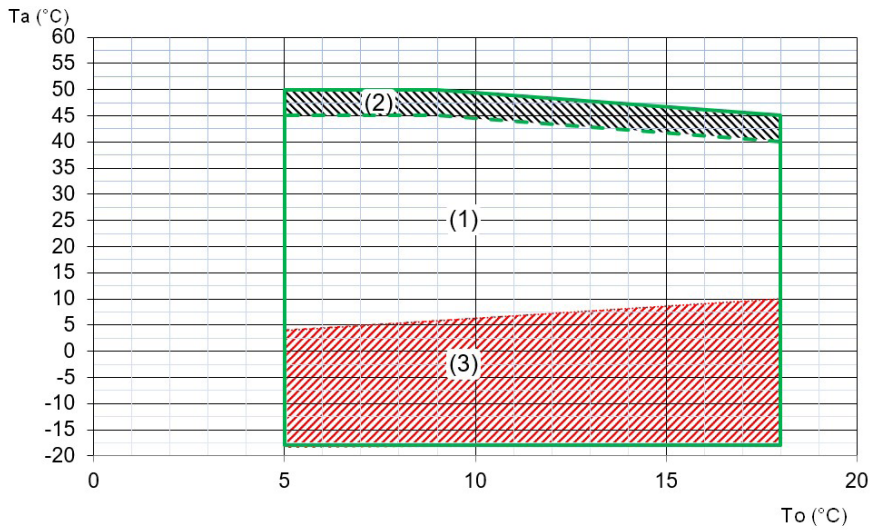

1. Standard unit operating range at full load
2. Unit operating range with automatic staging of the compressor capacity
3. Standard unit operating range with air flow automatic modulation

Operating range - Excellence / Premium (Acoustic configuration EN)

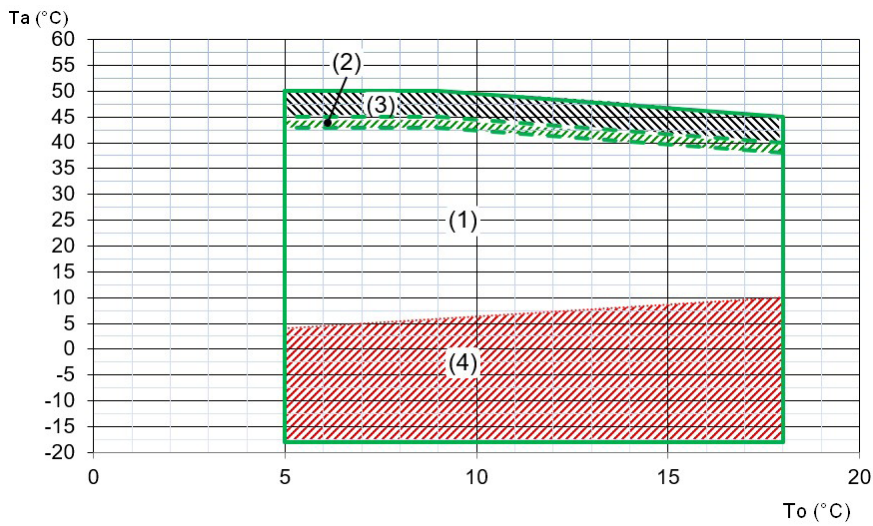

1. Standard unit operating range at full load
2. Extended operating range with air flow-rate automatic increasing. Inside this field the sound levels are the same of the 'compressor soundproofing (SC)' acoustic configuration
3. Unit operating range with automatic staging of the compressor capacity
4. Standard unit operating range with air flow automatic modulation

Excellence - Premium

Plate exchangers pressure drop (EVPHE)

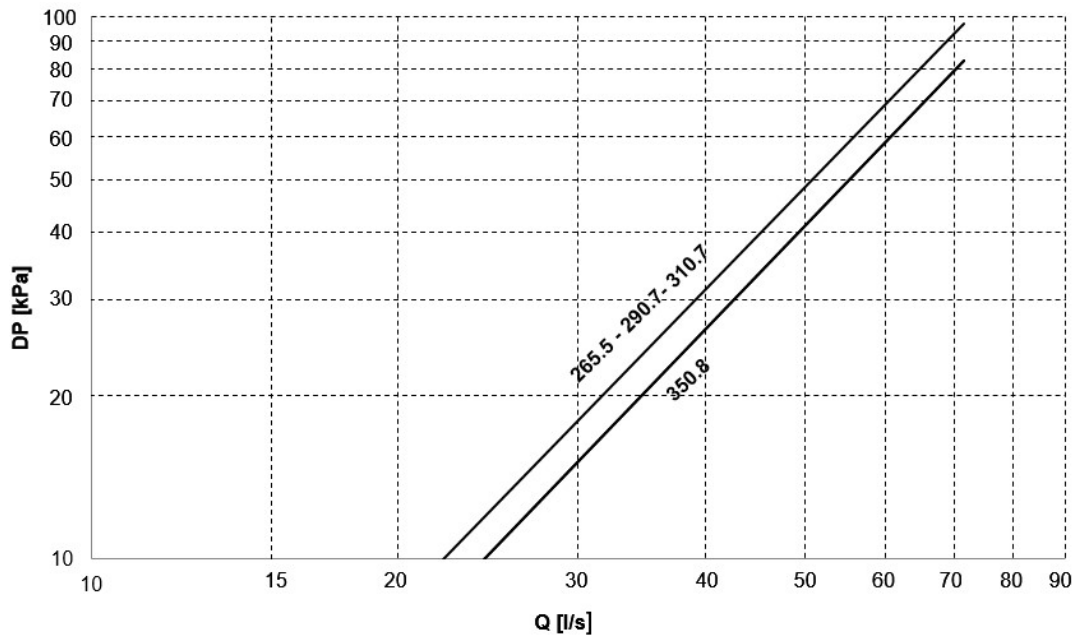

The pressure drops are calculated considering a water temperature of 7°C

Q = Water flow rate [l/s]

DP = Water side pressure drops [kPa]

The water flow rate must be calculated with the following formula

$$Q \text{ [l/s]} = \frac{kWf}{4,186 \times DT}$$

kWf = Cooling capacity in kW

DT = Temperature difference between inlet / outlet water

Admissible water flow rates

Minimum (Qmin) and maximum (Qmax) admissible water flow rates for correct operation of the unit.

SIZE		265.6	290.7	310.7	350.8
Qmin	[l/s]	22,1	22,1	22,1	24,3
Qmax	[l/s]	71,7	71,7	71,7	71,7

General technical data

Correction factors for ethylene glycol use

% ETHYLENE GLYCOL BY WEIGHT		5%	10%	15%	20%	25%	30%	35%	40%	45%	50%
Freezing temperature	°C	-2	-3,9	-6,5	-8,9	-11,8	-15,6	-19,0	-23,4	-27,8	-32,7
Safety temperature	°C	3	1	-1	-4	-6	-10	-14	-19	-23,8	-29,4
Cooling Capacity Factor	No.	0,997	0,994	0,990	0,986	0,981	0,976	0,970	0,964	0,957	0,950
Compressor power input Factor	No.	0,999	0,999	0,998	0,997	0,996	0,996	0,995	0,994	0,993	0,993
Internal exchanger pressure drop factor	No.	1,016	1,035	1,056	1,080	1,106	1,135	1,166	1,200	1,236	1,275

Correction factors for propylene glycol use

% PROPYLENE GLYCOL BY WEIGHT		5%	10%	15%	20%	25%	30%	35%	40%	45%	50%
Freezing temperature	°C	-2	-3,9	-6,5	-8,9	-11,8	-15,6	-19,0	-23,4	-27,8	-32,7
Safety temperature	°C	3	1	-1	-4	-6	-10	-14	-19	-23,8	-29,4
Cooling Capacity Factor	No.	0,995	0,990	0,983	0,976	0,968	0,960	0,950	0,939	0,928	0,916
Compressor power input Factor	No.	0,999	0,997	0,995	0,993	0,991	0,988	0,986	0,983	0,980	0,977
Internal exchanger pressure drop factor	No.	1,027	1,058	1,093	1,133	1,176	1,224	1,276	1,332	1,393	1,457

Fouling Correction Factors

INTERNAL EXCHANGER (EVAPORATOR)

M2 °C/W	F1	FK1
0,44 x 10 (-4)	1,0	1,0
0,88 x 10 (-4)	0,97	0,99
1,76 x 10 (-4)	0,94	0,98

F1 = Cooling capacity correction factors

FK1 = Compressor power input correction factor

Exchanger operating range

INTERNAL EXCHANGER (EVAPORATOR)

		DPR	DPW
Plate exchanger	PED (CE)	4700	1000
shell and tube exchanger	PED (CE)	3000	1000

DPr = Maximum operating pressure on refrigerant side in kPa

DPw = Maximum operating pressure on water side in kPa

Overload and control device calibrations

		OPEN	CLOSED	VALUE
High pressure switch	kPa	4230		-
Antifreeze protection	°C	4	5,5	-
High pressure safety valve	kPa	-	-	4700
Low pressure safety valve	kPa	-	-	3000
Max no. of compressor starts per hour	n°	-	-	10
Discharge safety thermostat	°C	-	-	150

Excellence Cooling - ST/SC

Size	To (°C)	Temperature of air entering the external exchanger (°C)											
		25		30		35		40		45		50	
		kWf	kWe	kWf	kWe	kWf	kWe	kWf	kWe	kWf	kWe	kWf	kWe
265.6	5	729	173	701	192	670	213	632	234	601	259	477	224
	6	756	175	727	195	695	216	656	237	618	261	492	226
	7	783	176	753	197	720	220	679	241	636	264	507	228
	10	849	180	817	202	782	225	738	247	676	268	-	-
	15	962	188	925	211	886	235	836	259	745	278	-	-
	18	1027	192	988	216	946	241	893	267	784	283	-	-
290.7	5	791	194	761	216	727	238	685	262	643	289	446	204
	6	820	196	788	218	754	242	710	265	666	292	460	206
	7	849	198	816	221	780	246	735	270	689	295	474	208
	10	920	204	884	227	846	252	797	277	747	304	-	-
	15	1040	213	1000	238	956	264	902	292	844	320	-	-
	18	1109	218	1066	245	1020	272	963	300	900	329	-	-
310.7	5	828	210	796	232	760	257	716	282	678	311	477	224
	6	858	212	824	235	788	261	742	286	698	314	492	226
	7	888	214	853	239	815	265	768	291	718	317	507	228
	10	961	220	924	246	883	273	832	299	763	325	-	-
	15	1085	231	1043	258	997	286	940	315	841	338	-	-
	18	1157	238	1111	266	1063	295	1003	325	886	346	-	-
350.8	5	953	235	916	261	876	288	825	317	775	349	572	268
	6	988	237	949	264	908	293	856	321	803	353	589	271
	7	1023	240	983	268	940	297	886	326	831	357	607	273
	10	1108	246	1065	274	1019	305	961	335	900	367	-	-
	15	1253	257	1204	288	1152	320	1087	352	1017	386	-	-
	18	1336	264	1284	296	1229	329	1160	363	1085	397	-	-

kWf = Cooling capacity in kW

kWe = Compressor power input in kW

To (°C) = Internal exchanger outlet water temperature (evaporator)

Performances in function of the inlet/outlet water temperature differential = 5°C

Excellence Cooling - EN

Size	To (°C)	Temperature of air entering the external exchanger (°C)											
		25		30		35		40		45		50	
		kWf	kWe	kWf	kWe	kWf	kWe	kWf	kWe	kWf	kWe	kWf	kWe
265.6	5	713	183	684	202	653	223	610	247	592	261	465	232
	6	739	185	709	205	677	227	635	249	603	259	479	234
	7	765	187	734	208	700	230	661	252	615	256	493	237
	10	828	193	795	214	759	237	724	257	638	249	-	-
	15	935	203	897	226	857	250	832	266	678	236	-	-
	18	997	209	956	233	914	258	894	271	700	229	-	-
290.7	5	771	206	740	227	706	251	658	278	638	291	435	212
	6	799	208	766	230	731	254	685	280	642	284	449	214
	7	827	211	792	233	755	258	712	282	645	276	462	216
	10	893	218	857	241	817	266	780	288	643	254	-	-
	15	1007	230	965	256	921	282	894	299	641	218	-	-
	18	1072	237	1028	264	981	292	961	305	638	195	-	-
310.7	5	809	222	775	245	739	270	688	299	669	312	465	232
	6	837	225	802	249	765	274	716	302	674	305	479	234
	7	866	228	829	252	790	278	745	304	679	298	493	237
	10	935	236	896	262	854	288	816	311	680	276	-	-
	15	1052	251	1008	278	962	306	935	322	685	240	-	-
	18	1119	259	1072	287	1023	317	1004	329	686	218	-	-
350.8	5	934	249	896	275	855	303	797	336	775	352	557	278
	6	967	252	928	279	885	309	830	339	783	345	574	281
	7	1001	255	960	284	915	314	863	343	791	339	591	284
	10	1082	264	1038	292	990	324	945	349	801	319	-	-
	15	1219	278	1169	309	1116	342	1084	361	820	286	-	-
	18	1298	287	1245	319	1189	353	1164	369	829	266	-	-

kWf = Cooling capacity in kW

kWe = Compressor power input in kW

To (°C) = Internal exchanger outlet water temperature (evaporator)

Performances in function of the inlet/outlet water temperature differential = 5°C

Prerformance

Premium Cooling - ST/SC

Size	To (°C)	Temperature of air entering the external exchanger (°C)											
		25		30		35		40		45		50	
		kWf	kWe	kWf	kWe	kWf	kWe	kWf	kWe	kWf	kWe	kWf	kWe
265.6	5	729	173	701	192	670	213	632	234	601	259	477	224
	6	756	175	727	195	695	216	656	237	618	261	492	226
	7	783	176	753	197	720	220	679	241	636	264	507	228
	10	849	180	817	202	782	225	738	247	676	268	-	-
	15	962	188	925	211	886	235	836	259	745	278	-	-
	18	1027	192	988	216	946	241	893	267	784	283	-	-
290.7	5	791	194	761	216	727	238	685	262	643	289	446	204
	6	820	196	788	218	754	242	710	265	666	292	460	206
	7	849	198	816	221	780	246	735	270	689	295	474	208
	10	920	204	884	227	846	252	797	277	747	304	-	-
	15	1040	213	1000	238	956	264	902	292	844	320	-	-
	18	1109	218	1066	245	1020	272	963	300	900	329	-	-
310.7	5	828	210	796	232	760	257	716	282	678	311	477	224
	6	858	212	824	235	788	261	742	286	698	314	492	226
	7	888	214	853	239	815	265	768	291	718	317	507	228
	10	961	220	924	246	883	273	832	299	763	325	-	-
	15	1085	231	1043	258	997	286	940	315	841	338	-	-
	18	1157	238	1111	266	1063	295	1003	325	886	346	-	-
350.8	5	953	235	916	261	876	288	825	317	775	349	572	268
	6	988	237	949	264	908	293	856	321	803	353	589	271
	7	1023	240	983	268	940	297	886	326	831	357	607	273
	10	1108	246	1065	274	1019	305	961	335	900	367	-	-
	15	1253	257	1204	288	1152	320	1087	352	1017	386	-	-
	18	1336	264	1284	296	1229	329	1160	363	1085	397	-	-

kWf = Cooling capacity in kW

kWe = Compressor power input in kW

To (°C) = Internal exchanger outlet water temperature (evaporator)

Performances in function of the inlet/outlet water temperature differential = 5°C

Premium Cooling - EN

Size	To (°C)	Temperature of air entering the external exchanger (°C)											
		25		30		35		40		45		50	
		kWf	kWe	kWf	kWe	kWf	kWe	kWf	kWe	kWf	kWe	kWf	kWe
265.6	5	713	184	684	204	653	225	610	249	592	259	463	233
	6	739	186	709	206	677	227	635	251	603	257	477	236
	7	765	188	734	209	700	231	660	253	615	255	492	238
	10	828	194	794	216	758	238	724	257	638	248	-	-
	15	934	205	896	228	856	252	831	265	677	238	-	-
	18	996	211	955	235	913	261	893	270	699	231	-	-
290.7	5	773	207	740	229	705	252	655	280	641	287	434	213
	6	801	210	766	232	730	255	682	282	644	280	447	215
	7	828	212	793	235	755	260	710	283	647	273	461	217
	10	895	220	857	243	816	268	779	288	644	253	-	-
	15	1008	232	965	258	919	284	897	296	641	219	-	-
	18	1074	240	1028	267	979	294	965	301	638	198	-	-
310.7	5	811	224	776	247	739	272	685	302	672	308	463	233
	6	840	227	804	251	765	276	714	304	677	301	477	236
	7	868	230	831	254	790	280	743	305	682	295	492	238
	10	937	239	897	264	853	290	815	311	682	275	-	-
	15	1054	253	1008	280	960	308	938	320	685	241	-	-
	18	1122	262	1073	290	1021	319	1009	325	686	221	-	-
350.8	5	937	251	898	277	855	305	794	339	778	347	555	280
	6	971	254	929	281	885	311	828	341	786	341	572	282
	7	1004	257	961	286	915	316	861	344	794	335	589	285
	10	1085	266	1039	295	990	326	945	348	803	317	-	-
	15	1222	281	1170	312	1115	344	1087	358	820	287	-	-
	18	1301	291	1246	323	1187	356	1169	363	829	269	-	-

kWf = Cooling capacity in kW

kWe = Compressor power input in kW

To (°C) = Internal exchanger outlet water temperature (evaporator)

Performances in function of the inlet/outlet water temperature differential = 5°C

Excellence

Cooling at part load - ST/SC

Size	Load	Temperature of air entering the external exchanger (°C)											
		35°C			30°C			25°C			20°C		
		kWf	kWe_tot	EER	kWf	kWe_tot	EER	kWf	kWe_tot	EER	kWf	kWe_tot	EER
265.6	100	720	231	3,12	753	209	3,60	783	188	4,16	810	168	4,82
	75	540	158	3,41	565	143	3,95	587	128	4,58	608	114	5,35
	50	360	94	3,83	376	85	4,45	391	76	5,18	405	66	6,11
	25	180	43	4,19	188	38	4,90	196	34	5,78	203	29	6,91
	Minimum	134	31	4,28	139	28	5,01	145	24	5,92	150	21	7,10
290.7	100	780	257	3,03	816	233	3,51	849	210	4,05	880	188	4,67
	75	585	175	3,34	612	158	3,87	637	141	4,53	660	125	5,28
	50	390	103	3,78	408	93	4,37	425	83	5,09	440	74	5,98
	25	195	47	4,16	204	42	4,87	212	37	5,75	220	32	6,86
	Minimum	134	31	4,28	139	28	5,01	145	24	5,92	150	21	7,10
310.7	100	815	277	2,94	853	251	3,40	888	226	3,93	920	203	4,53
	75	611	185	3,30	640	168	3,82	666	150	4,44	690	133	5,18
	50	408	111	3,66	427	101	4,24	444	90	4,94	460	79	5,81
	25	204	49	4,15	213	44	4,86	222	39	5,73	230	34	6,84
	Minimum	134	31	4,28	139	28	5,01	145	24	5,92	150	21	7,10
350.8	100	940	311	3,02	983	281	3,49	1023	254	4,03	1059	228	4,65
	75	705	211	3,34	737	191	3,87	767	171	4,48	794	152	5,23
	50	470	124	3,78	492	112	4,38	511	100	5,10	530	88	6,00
	25	235	55	4,29	246	49	5,03	256	43	5,95	265	37	7,13
	Minimum	134	31	4,29	140	28	5,03	145	24	5,94	150	21	7,13

Load = Percentage of cooling capacity compared to full load value

kWf = Cooling capacity in kW

kWe_tot = Overall electrical capacity input by the unit in kW

Internal heat exchanger water temperature = outlet 7°C / inlet 12°C / variable flow-rate with external exchanger air T.

Excellence

Cooling at part load - EN

Size	Load	Temperature of air entering the external exchanger (°C)											
		35°C			30°C			25°C			20°C		
		kWf	kWe_tot	EER	kWf	kWe_tot	EER	kWf	kWe_tot	EER	kWf	kWe_tot	EER
265.6	100	700	238	2,94	734	215	3,41	765	194	3,94	793	174	4,55
	75	525	158	3,32	550	143	3,85	574	128	4,47	595	114	5,23
	50	350	91	3,86	367	82	4,49	382	73	5,26	397	64	6,21
	25	175	42	4,19	183	37	4,91	191	33	5,79	198	29	6,92
	Minimum	134	31	4,28	139	28	5,01	145	24	5,92	150	21	7,10
290.7	100	755	265	2,85	792	240	3,30	827	218	3,80	858	196	4,37
	75	566	175	3,24	594	158	3,76	620	141	4,40	644	125	5,13
	50	378	99	3,81	396	89	4,43	413	80	5,18	429	70	6,10
	25	189	45	4,17	198	41	4,88	207	36	5,76	215	31	6,88
	Minimum	134	31	4,28	139	28	5,01	145	24	5,92	150	21	7,10
310.7	100	790	285	2,77	829	259	3,20	866	235	3,68	899	212	4,24
	75	593	186	3,19	622	168	3,69	649	151	4,29	674	135	5,00
	50	395	109	3,61	415	99	4,20	433	88	4,90	450	78	5,76
	25	198	47	4,16	207	43	4,87	216	38	5,74	225	33	6,85
	Minimum	134	31	4,28	139	28	5,01	145	24	5,92	150	21	7,10
350.8	100	915	322	2,84	960	292	3,29	1001	263	3,80	1039	237	4,38
	75	686	213	3,23	720	192	3,74	751	173	4,34	779	154	5,06
	50	458	121	3,77	480	109	4,39	500	98	5,13	519	86	6,04
	25	229	53	4,29	240	48	5,03	250	42	5,95	260	36	7,13
	Minimum	134	31	4,29	140	28	5,03	145	24	5,94	150	21	7,13

Load = Percentage of cooling capacity compared to full load value

kWf = Cooling capacity in kW

kWe_tot = Overall electrical capacity input by the unit in kW

Internal heat exchanger water temperature = outlet 7°C / inlet 12°C / variable flow-rate with external exchanger air T.

Prerformance

Premium

Cooling at part load - ST/SC

Size	Load	Temperature of air entering the external exchanger (°C)											
		35°C			30°C			25°C			20°C		
		kWf	kWe_tot	EER	kWf	kWe_tot	EER	kWf	kWe_tot	EER	kWf	kWe_tot	EER
265.6	100	720	231	3,12	753	209	3,60	783	188	4,16	810	168	4,82
	75	540	160	3,37	565	145	3,90	587	130	4,53	608	115	5,28
	50	360	96	3,77	376	86	4,36	391	77	5,07	405	68	5,96
	25	180	46	3,89	188	42	4,49	196	37	5,22	203	33	6,13
	Minimum	136	35	3,89	142	32	4,49	147	28	5,21	152	25	6,11
290.7	100	780	257	3,03	816	233	3,51	849	210	4,05	880	188	4,67
	75	585	177	3,31	612	160	3,83	637	142	4,47	660	127	5,21
	50	390	104	3,74	408	94	4,32	425	84	5,04	440	74	5,91
	25	195	50	3,89	204	45	4,49	212	41	5,22	220	36	6,13
	Minimum	136	35	3,89	142	32	4,49	147	28	5,21	152	25	6,11
310.7	100	815	277	2,94	853	251	3,40	888	226	3,93	920	203	4,53
	75	611	187	3,26	640	169	3,78	666	152	4,39	690	135	5,11
	50	408	114	3,59	427	103	4,15	444	92	4,82	460	82	5,64
	25	204	52	3,89	213	47	4,49	222	43	5,22	230	38	6,14
	Minimum	136	35	3,89	142	32	4,49	147	28	5,21	152	25	6,11
350.8	100	940	311	3,02	983	281	3,49	1023	254	4,03	1059	228	4,65
	75	705	213	3,30	737	193	3,82	767	173	4,43	794	154	5,16
	50	470	127	3,71	492	114	4,29	511	102	4,99	530	90	5,85
	25	235	60	3,90	246	55	4,50	256	49	5,23	265	43	6,14
	Minimum	137	35	3,90	142	32	4,50	147	28	5,23	152	25	6,14

Load = Percentage of cooling capacity compared to full load value

kWf = Cooling capacity in kW

kWe_tot = Overall electrical capacity input by the unit in kW

Internal heat exchanger water temperature = outlet 7°C / inlet 12°C / variable flow-rate with external exchanger air T.

Premium

Cooling at part load - EN

Size	Load	Temperature of air entering the external exchanger (°C)											
		35°C			30°C			25°C			20°C		
		kWf	kWe_tot	EER	kWf	kWe_tot	EER	kWf	kWe_tot	EER	kWf	kWe_tot	EER
265.6	100	700	243	2,88	734	220	3,34	765	200	3,83	794	180	4,41
	75	525	164	3,21	550	148	3,71	574	134	4,29	595	119	4,99
	50	350	95	3,67	367	86	4,25	382	77	4,94	397	69	5,78
	25	175	45	3,86	183	41	4,46	191	37	5,18	198	33	6,08
	Minimum	135	35	3,87	141	32	4,47	146	28	5,19	151	25	6,09
290.7	100	755	271	2,79	793	246	3,22	828	224	3,70	861	202	4,26
	75	566	180	3,14	595	164	3,63	621	147	4,23	646	131	4,91
	50	378	104	3,64	396	94	4,21	414	85	4,89	431	75	5,72
	25	189	49	3,85	198	45	4,45	207	40	5,17	215	35	6,08
	Minimum	135	35	3,87	141	32	4,47	146	28	5,19	151	25	6,09
310.7	100	790	291	2,71	831	265	3,13	868	241	3,60	903	219	4,13
	75	593	192	3,09	623	175	3,56	651	158	4,13	677	141	4,80
	50	395	114	3,46	415	104	4,00	434	94	4,64	452	83	5,41
	25	198	51	3,85	208	47	4,45	217	42	5,17	226	37	6,08
	Minimum	135	35	3,87	141	32	4,47	146	28	5,19	151	25	6,09
350.8	100	915	329	2,78	961	299	3,21	1004	271	3,71	1044	244	4,27
	75	686	220	3,12	721	200	3,61	753	180	4,18	783	161	4,85
	50	458	127	3,60	481	116	4,16	502	104	4,83	522	92	5,65
	25	229	59	3,88	240	54	4,49	251	48	5,21	261	43	6,12
	Minimum	136	35	3,88	141	32	4,48	147	28	5,21	151	25	6,12

Load = Percentage of cooling capacity compared to full load value

kWf = Cooling capacity in kW

kWe_tot = Overall electrical capacity input by the unit in kW

Internal heat exchanger water temperature = outlet 7°C / inlet 12°C / variable flow-rate with external exchanger air T.

ST - Standard acoustic configuration

The units is supplied with SCROLL compressors without soundproofing casing.

- ⚠ With the standard acoustic configuration if the hydronic units installed on the unit are selected, they are supplied without casing.

To find out the standard unit sound level, refer to the 'Sound levels' tables.



SC - Acoustic configuration with compressor soundproofing

Configuration used to increase the unit's silent operation by acting on the source of the noise. It consists of suitable steel casings lined with high-density material designed to provide sound insulation. The casings are secured to an aluminium frame and painted on the outside with polyester powder (RAL 9001).

- ⚠ With the acoustic configuration with compressor soundproofing if the hydronic units installed on the unit are selected, they are supplied without casing.

To assess the quality of the soundproofing benefit, refer to the 'Sound levels' tables.



EN - Super-silenced acoustic configuration

Configuration that further increases the unit's silent operation by acting on the source of the noise. It consists of suitable steel casings lined with high-density material designed to provide sound insulation. The casings are secured to an aluminium frame and painted on the outside with polyester powder (RAL 9001).

The unit also reduces the air flow.

- ⚠ With the super-silenced acoustic configuration, if the hydronic units installed on the unit are selected, they are supplied with casing.

To assess the benefit of the super silenced configuration, refer to the "Sound levels" tables.



PPBM - Microchannel coils protection panels

Microchannel coils protection panels supplied on the manifold side.

They guarantee greater protection during transport and from accidental contact with things or people.



Standard Unit



Unit with option PPBM

Configurations

PFGP - Soundproofing paneling of the pumping unit

Configuration used to increase the hydronic assembly's silent operation.

It is made up of steel casings lined internally with high-density material with a soundproofing function. The casings are pre-painted with RAL 9001 color.

Option available for all pumping groups installed on the unit, in combination with the standard acoustic configuration (ST) and with compressor soundproofing (SC)

CCME - E-coated microchannel coil

The full aluminium microchannel coil is completely treated by electrolysis so as to create a protective layer of epoxy polymer on the surface, with the following characteristics:

- over 3000 hours of protection against salt spray (ASTM G85 A3 - SWAAT);
- over 2000 hours of protection against UV rays (ASTM G155-05a)
- provide a very high resistance against corrosion

Categories of atmospheric corrosion

Atmospheric corrosion is divided into six categories of corrosivity level, as shown in table.

Corrosivity	ISO 9223 Category	Corrosion rate for aluminium g/m2
Very low	C1	negligible
Low	C2	$r_{corr} \leq 0.6$
Medium	C3	$0.6 < r_{corr} \leq 2$
High	C4	$2 < r_{corr} \leq 5$
Very high	C5	$5 < r_{corr} \leq 10$
Extreme	CX	$r_{corr} > 10$

Atmospheric Corrosivity category (ISO 9223)	C1, C2	C3 (inland)	C3 (coastal)	C4	C5	CX
Corrosivity	Very low, low	Medium	Medium	High	Very high	Extreme
Typical environments	Indoor, Rural areas	Urban areas	Urban areas	Polluted Urban, industrial, coastal areas	Very high pollution & salt deposition areas	Extreme industrial, coastal areas
CCM - Microchannel coil (standard)	OK	OK	NR	NR	NR	NR
CCME - E-coated microchannel coil	OK	OK	OK	OK	AP	AP

OK: Recommended;

AP: Acceptable, life may be shorter;

NR: Not recommended

Partial energy recovery

A configuration which enables the production of hot water free-of-charge while operating in the cooling mode, thanks to the partial recovery of condensation heat that would otherwise be disposed of into the external heat source.

This option is also known as “desuperheater”. It is made up of a Inox 316 stainless steel brazed plate heat exchangers, suitable for recovering a part of the capacity dispersed by the unit (the dispersed heating capacity is equal to the sum of the cooling capacity and the electrical input capacity of the compressors).

The partial recovery device is considered to be operating when it is powered by the water flow which is to be heated. This condition improves the unit performance, since it reduces the condensation temperature: in nominal conditions the cooling capacity increases indicatively by 3.2% and the power input of the compressors is reduced by 3.6%.

When the temperature of the water to be heated is particularly low, it is opportune to insert a flow regulation valve in the hydraulic circuit, to maintain the recovery output temperature at higher than 35°C and thus avoid refrigerant condensation in the partial energy recovery device.

The partial energy recovery water connections are 2” 1/2 for all sizes.

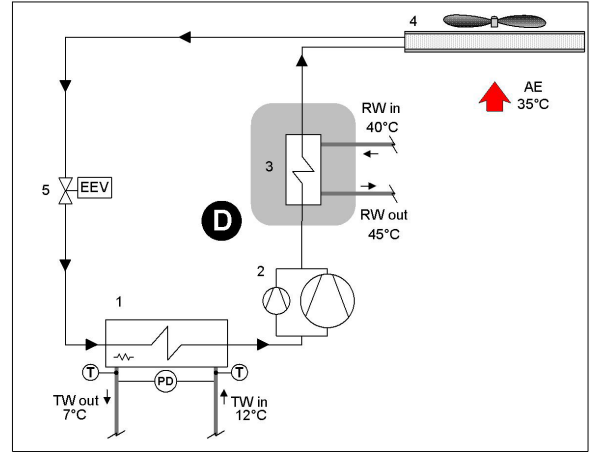

D - Partial recovery device

- 1 - Internal exchanger
- 2 - Compressors
- 3 - Recovery exchanger
- 4 - External exchanger
- 5 - Electronic expansion valve

- TW in Chilled water inlet
- TW out Chilled water outlet
- RW in - Ingresso acqua recupero
- RW out - Uscita acqua recupero

- T - Temperature probe
- PD - Differential pressure switch
- AE Aria esterna

Partial recovery heating capacity

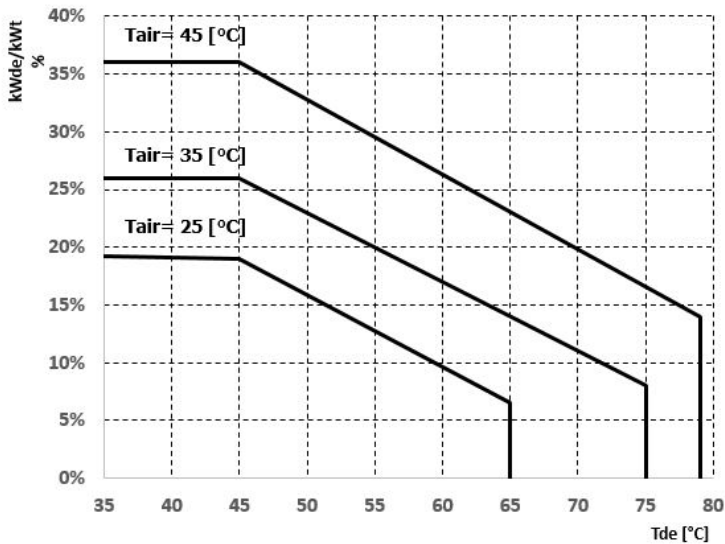

$kWde/kWf = \text{Heat recovered} / \text{Condenser heating capacity (cooling capacity + compressor power input)} [\%]$
 $Tde = \text{Heat recovering device outlet water temperature } [^{\circ}\text{C}]$

⚠ Values with a tolerance of $\pm 2\%$

Configurations

Partial energy recovery exchanger pressure drops - Excellence - Premium

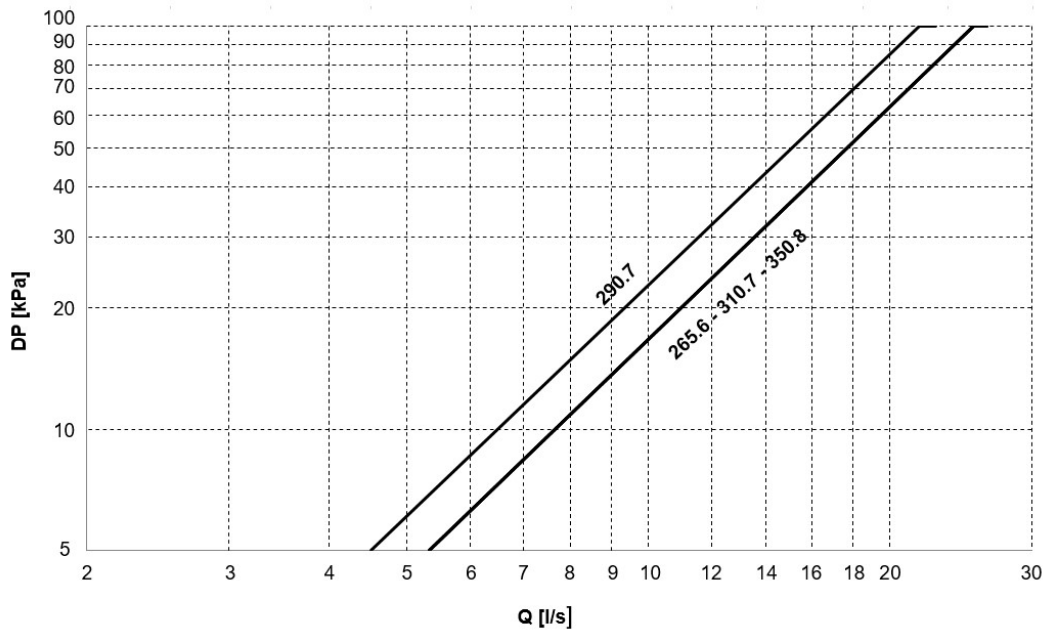

Q = Water flow rate [l/s]
DP = Water side pressure drops [kPa]

Admissible water flow rates

Minimum (Qmin) and maximum (Qmax) admissible water flow rates for correct operation of the unit.

SIZE		265.6	290.7	310.7	350.8
Qmin	[l/s]	5,3	4,5	5,3	5,3
Qmax	[l/s]	25,4	21,8	25,4	25,4

EVFTP - Shell and tube exchanger PED test

Direct expansion exchanger with two independent circuit refrigerant side. The exchanger is composed of a cover made of carbon steel. The tubes, anchored to the tube plate by mechanical expansion, are made of copper, high efficiency, internally rifled to improve thermal exchange and specially designed for use with modern ecological refrigerants. It also includes a water side protection differential switch, an anti-freeze heating element to protect against icing, and covering in closed-cell thermo-insulating material that prevents the formation of condensation and heat exchange with the exterior.

The water connections of the exchanger are quick-release with splined joint (Victaulic).

Shell and Tube Evaporator Pressure Drops (EVFTP) - Excellence / Premium

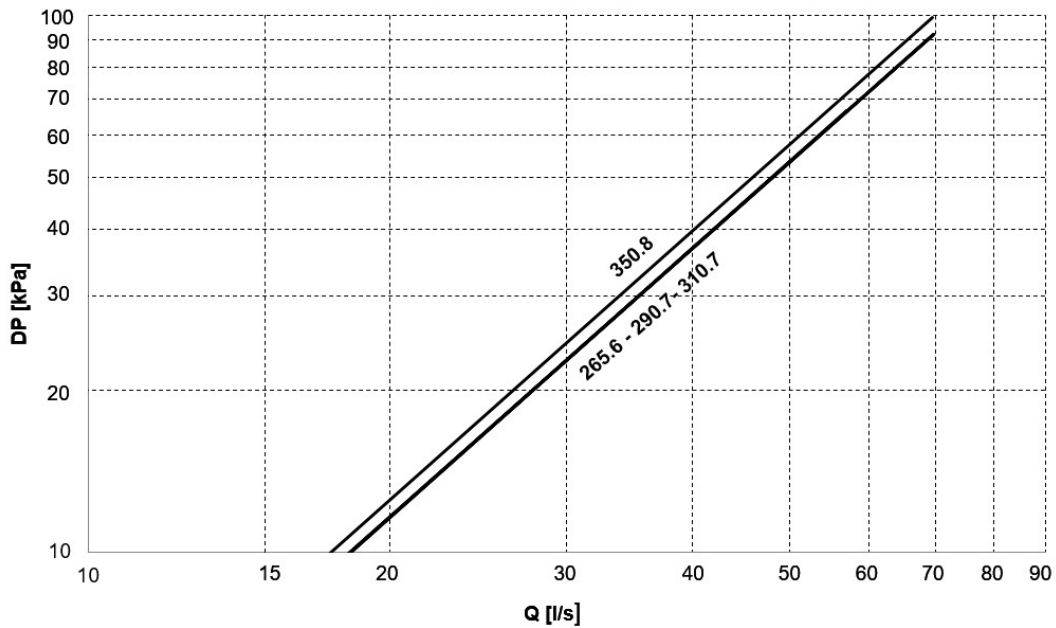

The pressure drops are calculated considering a water temperature of 7°C

Q = Water flow rate [l/s]

DP = Water side pressure drops [kPa]

The water flow rate must be calculated with the following formula

$$Q \text{ [l/s]} = \frac{kWf}{4,186 \times DT}$$

kWf = Cooling capacity in kW

DT = Temperature difference between inlet / outlet water

Admissible water flow rates

Min. (Qmin) and max. (Qmax) water flow-rates admissibles for the correct unit operation.

SIZE		265.6	290.7	310.7	350.8
Qmin	[l/s]	18,2	18,2	18,2	17,5
Qmax	[l/s]	57,1	69,6	69,6	69,4

Accessories - Hydronic assembly

2PM - Hydropack user side with N° 2 pumps

Pumping group consisting of two parallel electric pumps with a self-adaptive modular activation logic.

Electric centrifugal pump with cast iron pump body and stainless steel or cast iron impeller (depending on the model).

Mechanical seal using ceramic, carbon and EPDM elastomer components.

Three-phase electric motor with IP55 protection rating. Complete with thermoformed insulating casing, quick-release couplings with an insulated casing, safety valve, pressure gauges, system load safety pressure switch, stainless steel immersion antifreeze heaters fitted on the supply and suction lines.

All water fittings are Victaulic.

Option supplied on the unit.

CONNECTION DIAGRAM - 2PM - Hydropack user side with N° 2 pumps

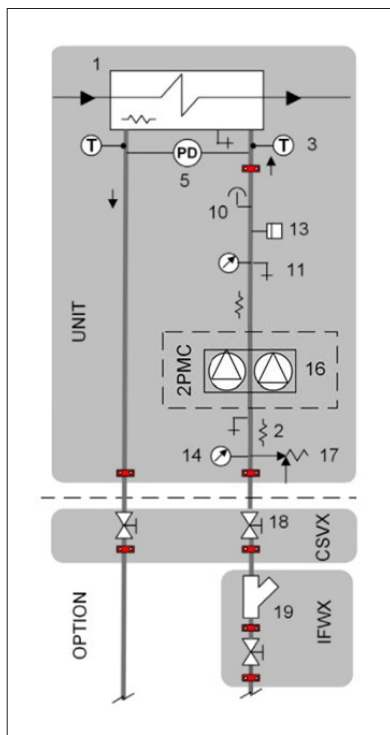

- 1 - Internal exchanger
- 2 - Cutoff valve - (CSVX Couple of manually operated shut-off valves)
- 3 - Purge valve
- 4 - Discharge stop valve
- 5 - Pressure gauge
- 6 - Safety valve (6 Bar)
- 7 - Packaged electric pump with high efficiency impeller
- 9 - System load safety pressure switch (it avoids the pump operation if water is not present)
- 10 - Antifreeze heater
- 11 - Steel mesh strainer water side (IFWX)
- 12 - Cutoff valve with quick joints

T - Temperature probe
PD - Differential pressure switch

TW in Chilled water inlet
TW out Chilled water outlet

The grey area indicates further optional components.

- ⚠ Provide hydraulic shut-off valves outside the unit (option: 'CSVX - Pair of manually operated shut-off valves') to facilitate any extraordinary maintenance operations.
- ⚠ It is necessary to provide a non-return valve for each unit installed in hydraulic parallel and equipped with an hydronic assembly installed on board (Installation by the Customer).

Hydropack electrical data

PUMP	Rated power [kW]	Rated current input [A]
2PM 265.6 ÷ 310.7	2 x 5,5	2 x 11,45
2PM 350.8	2 x 7,5	2 x 15,37

2PM - Hydropack user side with N° 2 pumps

Head

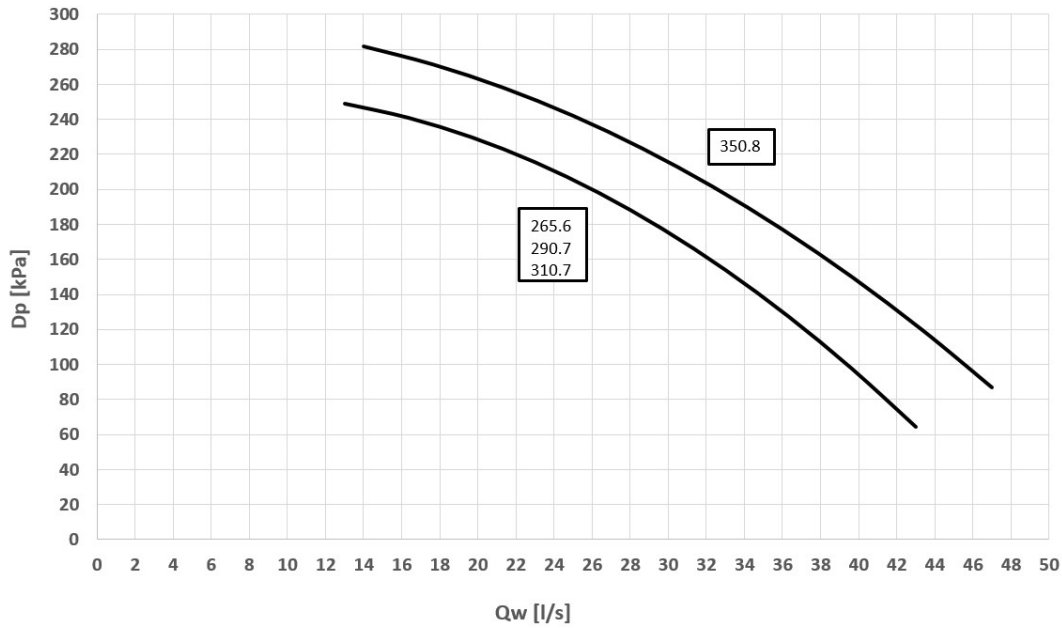

Dp = Pump head [kPa]
 QW = Water flow-rate [l/s]

Power input

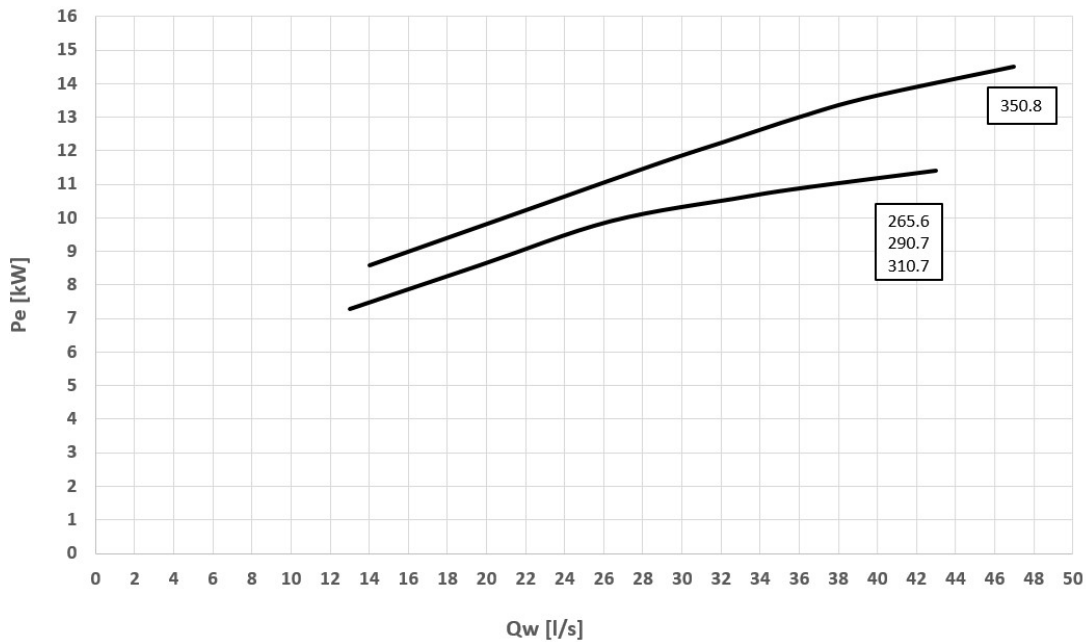

Pe = Power input [kW]
 QW = Water flow-rate [l/s]

⚠ Caution: to obtain the available pressure values, you need to subtract the following from the head values represented in these diagrams:
 User side exchanger pressure drops
 IFVX accessory - Steel mesh filter on the water side (where present)

Accessories - Hydronic assembly

2PMV - Hydropack user side with N° 2 inverter pumps

Pumping group consisting of parallel electric pumps controlled by inverter to adapt to different conditions of use.

Automatically reduces the liquid flow-rate in critical conditions, thereby preventing overloading blockages and the subsequent intervention of specialised technical personnel.

The pump flow-rate/head can be adapted to the system features by calibrating the inverter, which is standard supplied.

Electric centrifugal pump with cast iron pump body and stainless steel or cast iron impeller (depending on the model).

Mechanical seal using ceramic, carbon and EPDM elastomer components.

Three-phase electric motor with IP55 protection rating. Complete with thermoformed insulating casing, quick-release couplings with an insulated casing, safety valve, pressure gauges, system load safety pressure switch, stainless steel immersion antifreeze heaters fitted on the suction and supply lines.

In combination with the "IVFDT" - Variable flow-rate control option, it allows variation of the water flow-rate to the system under partial-load to achieve the highest unit efficiency and lower consumption of the pumping group.

All water fittings are Victaulic.

Option supplied on the unit.

CONNECTION DIAGRAM - 2PMV - Hydropack user side with N° 2 inverter pumps

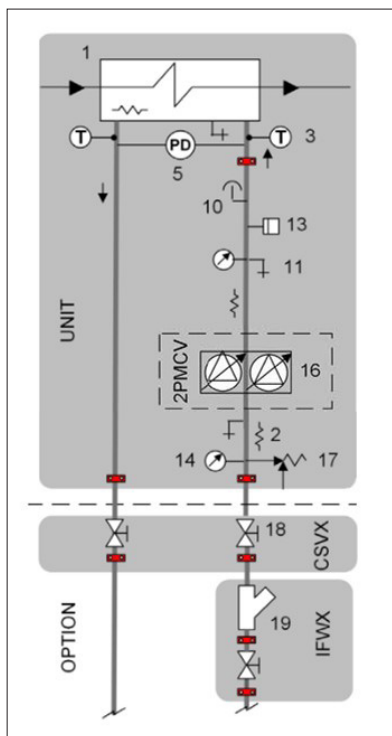

- 1 - Internal exchanger
- 2 - Cutoff valve - (CSVX Couple of manually operated shut-off valves)
- 3 - Purge valve
- 4 - Discharge stop valve
- 5 - Pressure gauge
- 6 - Safety valve (6 Bar)
- 7 - Packaged electric pump with high efficiency impeller
- 9 - System load safety pressure switch (it avoids the pump operation if water is not present)
- 10 - Antifreeze heater
- 11 - Steel mesh strainer water side (IFWX)
- 12 - Cutoff valve with quick joints

T - Temperature probe
PD - Differential pressure switch

TW in Chilled water inlet
TW out Chilled water outlet

The grey area indicates further optional components.

- ⚠ Provide hydraulic shut-off valves outside the unit (option: 'CSVX - Pair of manually operated shut-off valves') to facilitate any extraordinary maintenance operations.
- ⚠ It is necessary to provide a non-return valve for each unit installed in hydraulic parallel and equipped with an hydronic assembly installed on board (Installation by the Customer).

Hydropack electrical data

PUMP	Rated power [kW]	Rated current input [A]
2PMV 265.6 ÷ 310.7	2 x 5,5	2 x 11,45
2PMV 350.8	2 x 7,5	2 x 15,37

2PMV - Hydropack user side with N° 2 inverter pumps

Head - Gr. 265.6 - 290.7 - 310.7

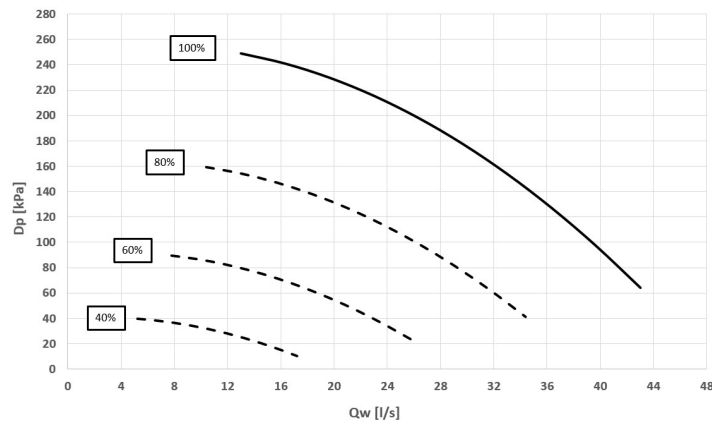

Dp = Pump head [kPa]
Qw = Water flow-rate [l/s]

Power input - Gr. 265.6 - 290.7 - 310.7

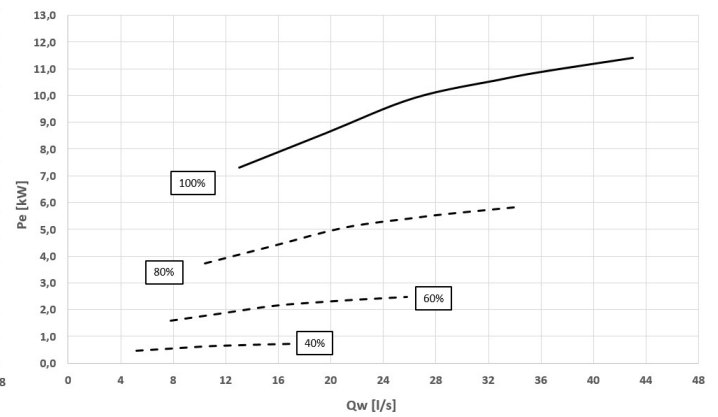

Pe = Power input [kW]
Qw = Water flow-rate [l/s]

Head - Gr. 350.8

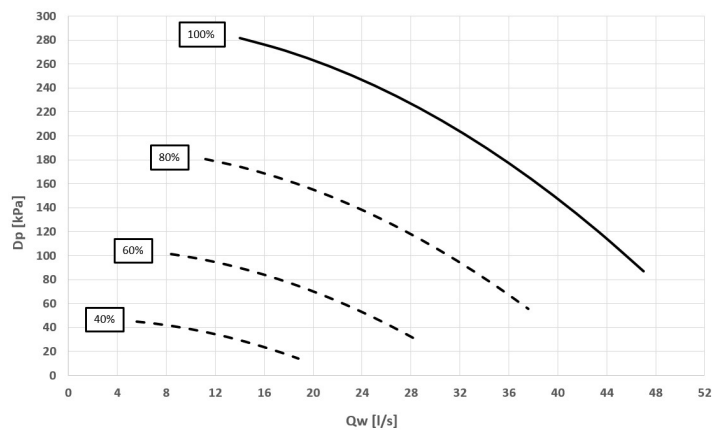

Dp = Pump head [kPa]
Qw = Water flow-rate [l/s]

Power input - Gr. 350.8

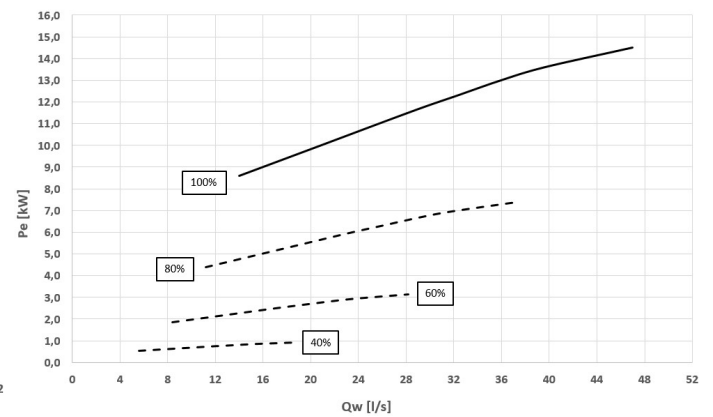

Pe = Power input [kW]
Qw = Water flow-rate [l/s]

⚠ Caution: to obtain the available pressure values, you need to subtract the following from the head values represented in these diagrams:
User side exchanger pressure drops
IFVX accessory - Steel mesh filter on the water side (where present)

Accessories - Hydronic assembly

1P1SB - Hydropack with 1 pump + 1 stand-by

Pumping group consisting of 1+1 electric pump (1 stand-by) with cast iron pump body and stainless steel or cast iron impeller (depending on the model). Mechanical seal using ceramic, carbon and EPDM elastomer components.

Three-phase electric motor with IP55 protection rating. Complete with thermoformed insulating casing, quick-release couplings with an insulated casing, safety valve, pressure gauges, system load safety pressure switch, stainless steel immersion antifreeze heaters fitted on the supply and suction lines.

All water fittings are Victaulic.

Option supplied on the unit.

CONNECTION DIAGRAM - 1P1SB - Hydropack with n°1 pump + n°1 stand-by pump

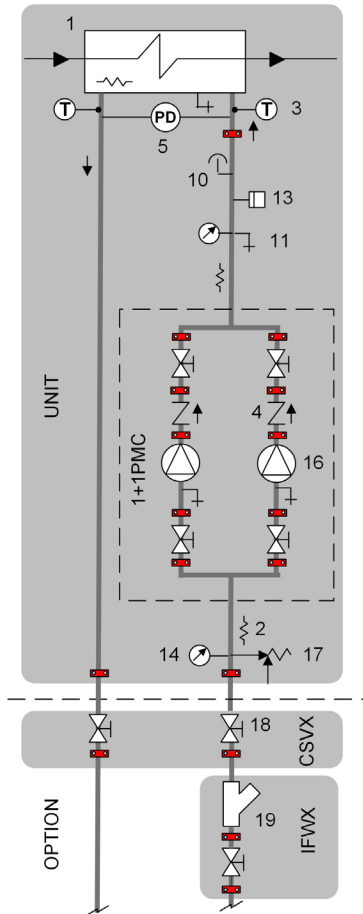

1. Exchanger
2. Antifreeze heater
3. Water temperature probe
4. Non return valve
5. Differential pressure switch
10. Vent
11. Drain
13. System load safety pressure switch
14. Pressure gauge
16. Packaged electric pump with high efficiency impeller
17. Pressure relief valve
18. Shut-off valve
19. Filter

T - Temperature probe
PD - Differential pressure switch

TW in Chilled water inlet
TW out Chilled water outlet

- ⚠ Provide hydraulic shut-off valves outside the unit (option: 'CSVX - Pair of manually operated shut-off valves') to facilitate any extraordinary maintenance operations.
- ⚠ The head and consumption graphs of the pumping group refer to operation with pure water. If there is a water-glycol mix, please contact Clivet's office to check the correct operating point of the pumping group.

Hydropack electrical data

PUMP	Rated power [kW]	Rated current input [A]
1P1SB 265.6 ÷ 310.7	7,5	15,48
1P1SB 350.8	11,0	22,89

1P1SB - Hydropack with 1 pump + 1 stand-by

Head

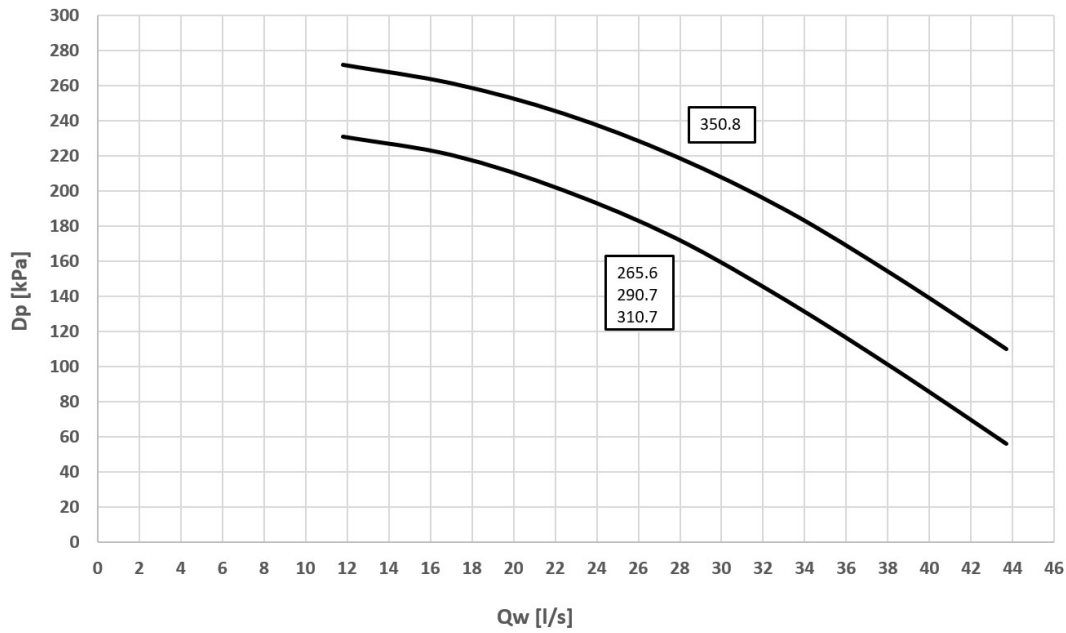

Dp = Pump head [kPa]
 QW = Water flow-rate [l/s]

Power input

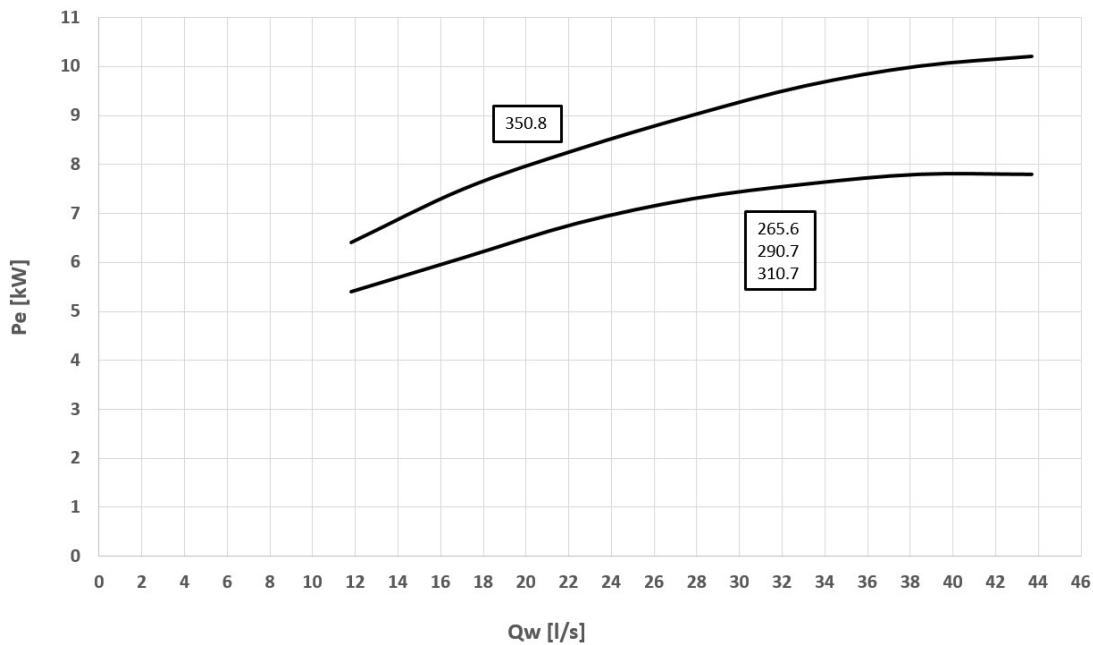

Pe = Power input [kW]
 QW = Water flow-rate [l/s]

Accessories - Hydronic assembly

1P1SBV - User side hydropack with 1 inverter pump and 1 stand-by pump with dedicated inverter

Pumping group consisting of 1+1 electric pump (1 stand-by) controlled by inverter to adapt to different conditions of use. Automatically reduces the liquid flow-rate in critical conditions, thereby preventing overloading blockages and the subsequent intervention of specialised technical personnel.

The pump flow-rate/head can be adapted to the system features by calibrating the inverter, which is standard supplied.

Electric centrifugal pump with cast iron pump body and stainless steel or cast iron impeller (depending on the model).

Mechanical seal using ceramic, carbon and EPDM elastomer components.

Three-phase electric motor with IP55 protection rating. Complete with thermoformed insulating casing, quick-release couplings with an insulated casing, safety valve, pressure gauges, system load safety pressure switch, stainless steel immersion antifreeze heaters fitted on the suction and supply lines.

In combination with the "IVFDT" - Variable flow-rate control option, it allows variation of the water flow-rate to the system under partial-load to achieve the highest unit efficiency and lower consumption of the pumping group.

All water fittings are Victaulic.

Option supplied on the unit.

CONNECTION DIAGRAM - Hydropack user side with n°1 inverter pump and n°1 stand-by pump with dedicated inverter

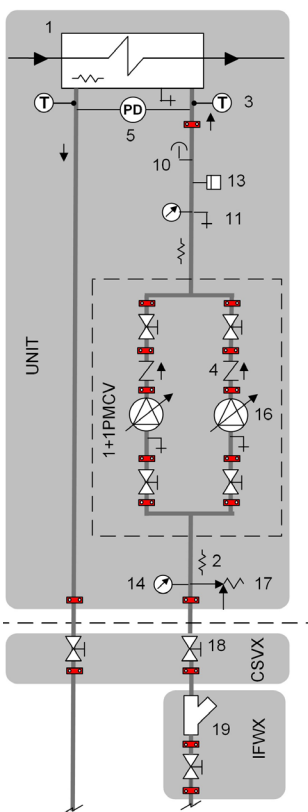

1. Exchanger
2. Antifreeze heater
3. Water temperature probe
4. Non return valve
5. Differential pressure switch
10. Vent
11. Drain
13. System load safety pressure switch
14. Pressure gauge
16. Packaged electric pump with high efficiency impeller
17. Pressure relief valve
18. Shut-off valve
19. Filter

T - Temperature probe
PD - Differential pressure switch

TW in Chilled water inlet
TW out Chilled water outlet

- ⚠ Provide hydraulic shut-off valves outside the unit (option: 'CSVX - Pair of manually operated shut-off valves') to facilitate any extraordinary maintenance operations.
- ⚠ The head and consumption graphs of the pumping group refer to operation with pure water. If there is a water-glycol mix, please contact Clivet's office to check the correct operating point of the pumping group.

Hydropack electrical data

PUMP	Rated power [kW]	Rated current input [A]
1P1SBV 265.6 ÷ 310.7	7,5	15,48
1P1SBV 350.8	11,0	22,89

Accessories - Hydronic assembly

1P1SBV - User side hydropack with 1 inverter pump and 1 stand-by pump with dedicated inverter

Head - Gr. 265.6 - 290.7 - 310.7

Power input - Gr. 265.6 - 290.7 - 310.7

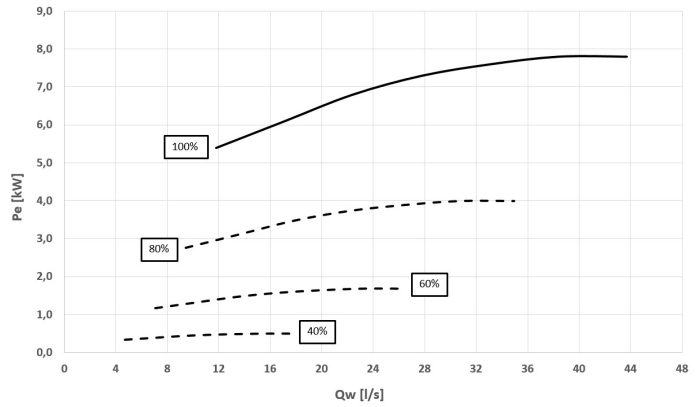
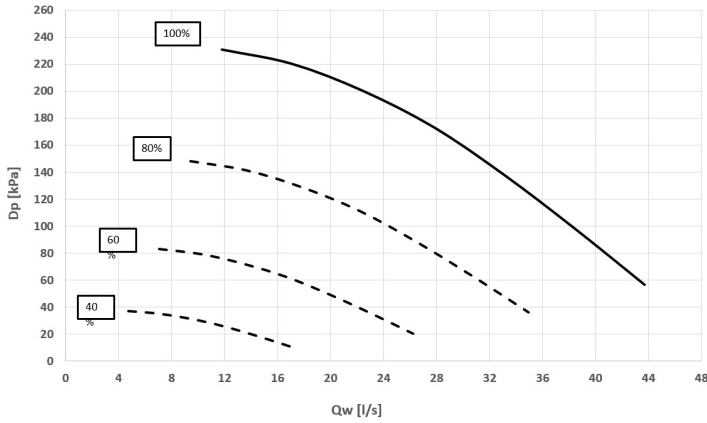

Dp = Pump head [kPa]
Qw = Water flow-rate [l/s]

Pe = Power input [kW]
Qw = Water flow-rate [l/s]

Head - Gr. 350.8

Power input - Gr. 350.8

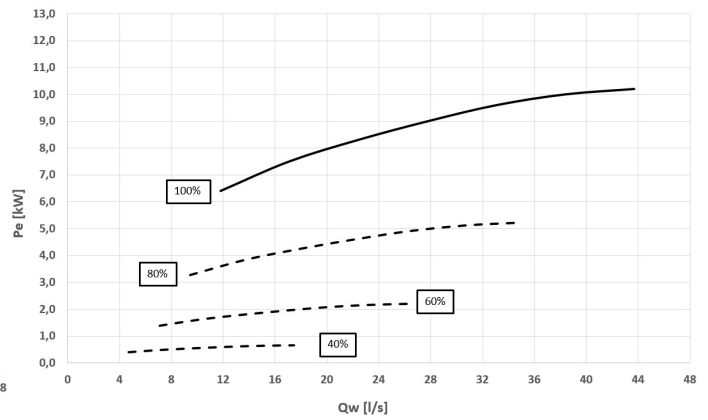
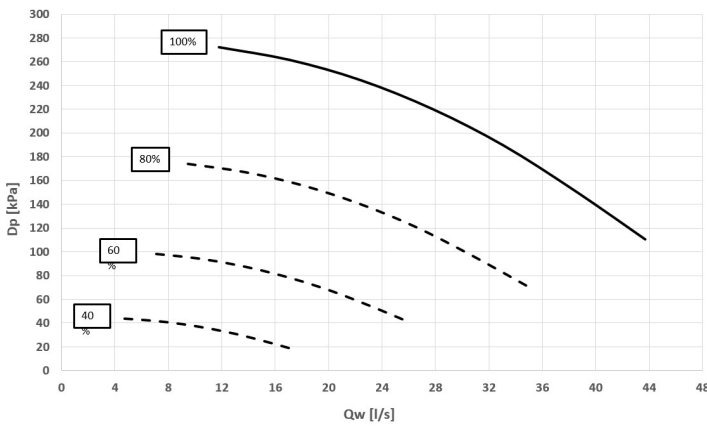

Dp = Pump head [kPa]
Qw = Water flow-rate [l/s]

Pe = Power input [kW]
Qw = Water flow-rate [l/s]

⚠ Caution: to obtain the available pressure values, you need to subtract the following from the head values represented in these diagrams:
User side exchanger pressure drops
IFVX accessory - Steel mesh filter on the water side (where present)

Option compatibility

REF	DESCRIPTION	265.6	290.7	310.7	350.8
Configurations and main accessories					
D	Partial energy recovery	0	0	0	0
ACC	Storage tank	0	0	0	0
ACC + D	Storage tank + Partial energy recovery	-	-	-	-
EVFTP	Shell and tube evaporator PED test	0	0	0	0
2PM	Hydropack user side with n°2 pumps	0	0	0	0
2PMV	Hydropack user with n°2 inverter pumps	0	0	0	0
1P1SB	Hydropack with 1 pump + 1 in stand-by	0	0	0	0
1P1SBV	User side hydropack with one inverter pump and one standby pump with dedicated inverter	0	0	0	0
EVFTP - Shell and tube evaporator PED test					
+ D	Partial energy recovery	0	0	0	0
+ 2PM	Hydropack user side with n°2 pumps	0	0	0	0
+ 2PMV	Hydropack user side with n°2 inverter pumps	0	0	0	0
+ 1P1SB	Hydropack with n° 1 pump + n° 1 in stand-by	0	0	0	0
+ 1P1SBV	User side hydropack with one inverter pump and one standby pump with dedicated inverter	0	0	0	0
+ D + 2PM	Partial energy recovery + Hydropack user side with n°2 pumps	-	-	-	-
+ D + 2PMV	Partial energy recovery + Hydropack user side with n°2 inverter pumps	-	-	-	-
+ D + 1P1SB	Partial energy recovery + User side hydropack with an inverter pump and a standby pump with dedicated inverter	-	-	-	-
+ D + 1P1SBV	Partial energy recovery + User side hydropack with an inverter pump and a standby pump with dedicated inverter	-	-	-	-
+ ACC	Storage tank	-	-	-	-
+ ACC + D	Storage tank + Partial energy recovery	-	-	-	-
2PM / 2PMV / 1P1SB / 1P1SBV					
+ D	Partial energy recovery	0	0	0	0
+ ACC	Storage tank	0	0	0	0
+ ACC + D	Storage tank + Partial energy recovery	-	-	-	-
IVFDT - User side inverter variable flow-rate control based on the temperature difference					
(2PM)	Hydropack user side with n°2 pumps	-	-	-	-
(2PMV)	Hydropack user with n°2 inverter pumps	0	0	0	0
(1P1SB)	Hydropack with 1 pump + 1 in stand-by	-	-	-	-
(1P1SBV)	User side hydropack with one inverter pump and one standby pump with dedicated inverter	0	0	0	0
Other accessories					
CREFB	Device to reduce the consumption levels of Eco Breeze fans on the external section	●	●	●	●
CREFP	Fan consumption reduction device of external section at variable speed (phase cutting)	●	●	●	●
SFSTR	Disposal for inrush current reduction	0	0	0	0

0 Option

- Not available

● Standard

SIZE 265.6 - 290.7 - 310.7 EXC/PRM

DAAT40008_00
DATA/DATE 27/09/2022

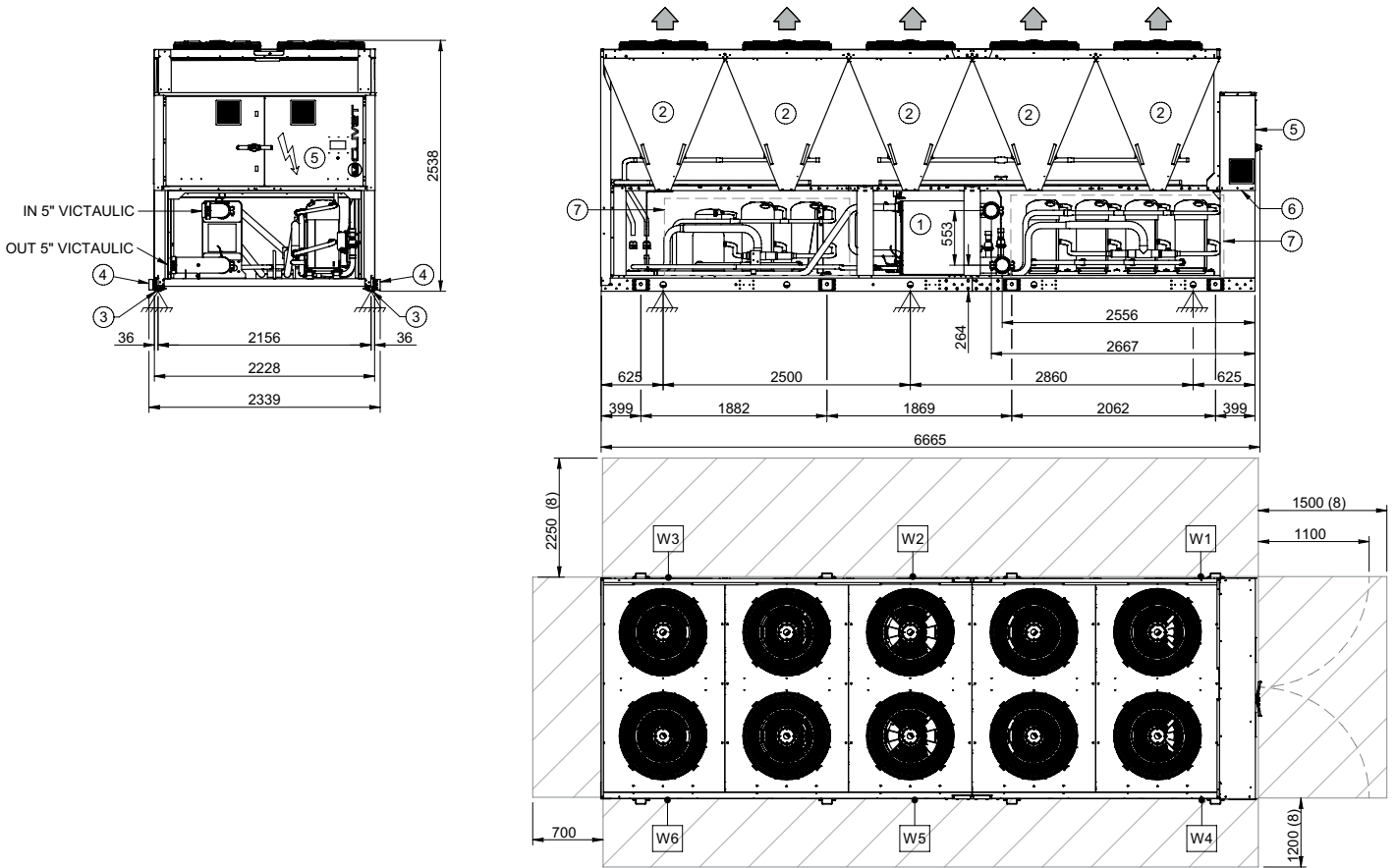

1. Internal exchanger (evaporator)
2. External exchanger (condenser)
3. Unit fixing holes
4. Lifting bracket (removed)
5. Electrical panel
6. Power input
7. Sound proof enclosure (optional)
8. Clearance access recommended

SIZE		265.6		290.7		310.7	
		ST	SC/EN	ST	SC/EN	ST	SC/EN
Length	mm	6665	6665	6665	6665	6665	6665
Depth	mm	2228	2228	2228	2228	2228	2228
Height	mm	2538	2538	2538	2538	2538	2538
W1 Support point	kg	700	750	814	872	812	870
W2 Support point	kg	957	1036	1009	1093	1027	1111
W3 Support point	kg	455	494	424	462	443	481
W4 Support point	kg	525	541	561	579	560	578
W5 Support point	kg	788	812	804	830	810	835
W6 Support point	kg	308	320	299	311	305	317
Operation weight	kg	3734	3954	3912	4147	3957	4192
Operating weight	kg	3636	3856	3814	4049	3859	4094

The presence of optional accessories may result in a substantial variation of the weights shown in the table.

Dimensional drawings

SIZE 350.8 EXC/PRM

DAAT40009_00
DATA/DATE 12/10/2022

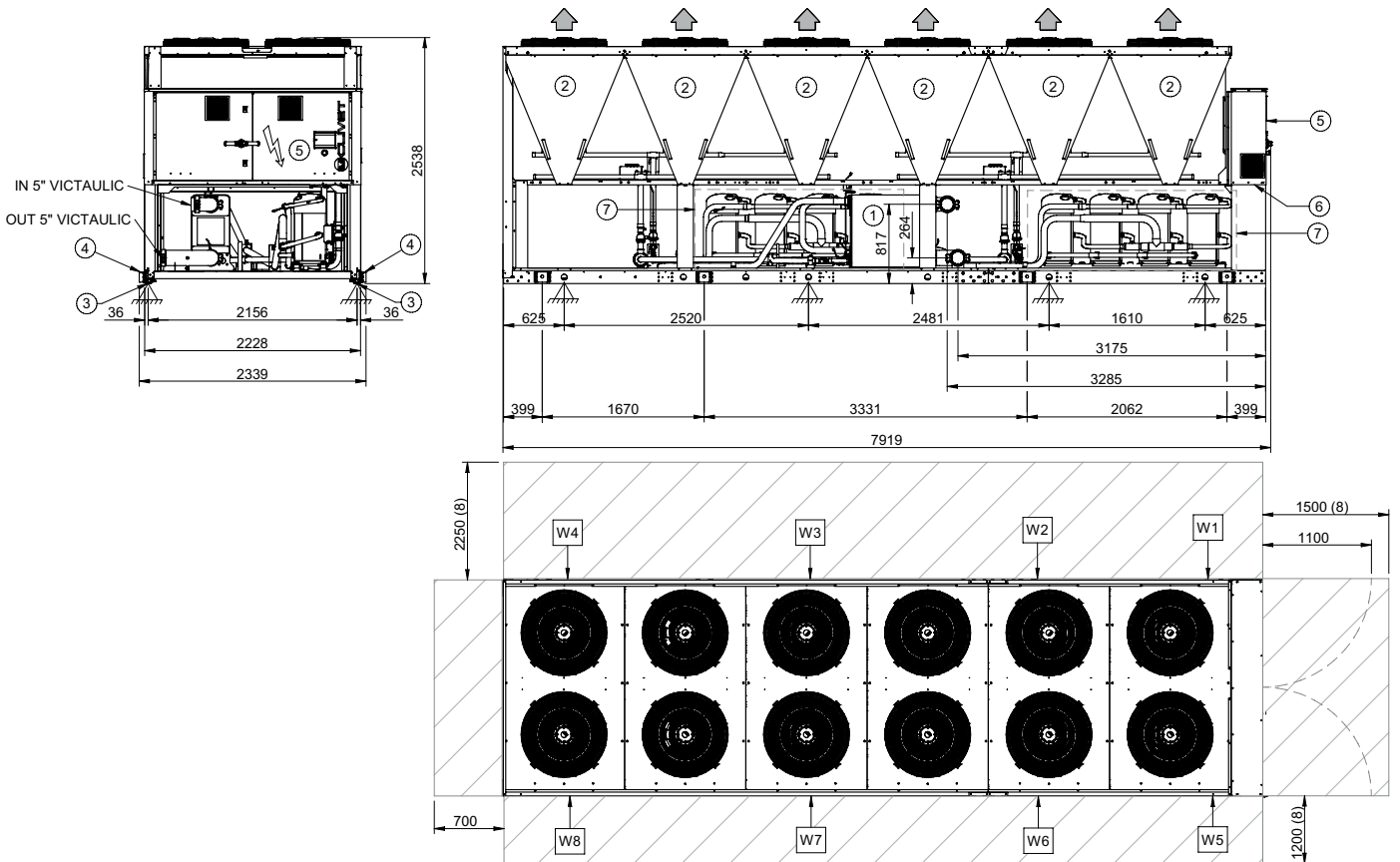

1. Internal exchanger (evaporator)
2. External exchanger (condenser)
3. Unit fixing holes
4. Lifting bracket (removed)
5. Electrical panel
6. Power input
7. Sound proof enclosure (optional)
8. Clearance access recommended

SIZE	350.8		
	ST	SC/EN	
Length	mm	7919	7919
Depth	mm	2228	2228
Height	mm	2538	2538
W1 Support point	kg	636	681
W2 Support point	kg	660	710
W3 Support point	kg	1034	1123
W4 Support point	kg	300	308
W5 Support point	kg	419	433
W6 Support point	kg	547	562
W7 Support point	kg	696	723
W8 Support point	kg	259	262
Operation weight	kg	4551	4801
Operating weight	kg	4441	4691

The presence of optional accessories may result in a substantial variation of the weights shown in the table.

FOR OVER 30 YEARS WE HAVE BEEN
OFFERING SOLUTIONS TO ENSURE
SUSTAINABLE COMFORT AND THE
WELL-BEING OF PEOPLE AND THE
ENVIRONMENT
www.clivet.com



sales and service

MideaGroup
humanizing technology



CLIVET S.p.A.

Via Camp Lonc 25, Z.I. Villapaiera 32032 - Feltre (BL) - Italy
Tel. +39 0439 3131 - info@clivet.it

CLIVET GMBH

Hummelsbütteler Steindamm 84,
22851 Norderstedt, Germany
Tel. +49 40 325957-0 - info.de@clivet.com

Clivet Group UK LTD

Units F5 & F6 Railway Triangle,
Portsmouth, Hampshire PO6 1TG
Tel. +44 02392 381235 -
Enquiries@Clivetgroup.co.uk

CLIVET LLC

Office 508-511, Elektrozavodskaya st. 24,
Moscow, Russian Federation, 107023
Tel. +7495 6462009 - info.ru@clivet.com

CLIVET MIDEAST FZCO

Dubai Silicon Oasis (DSO) Headquarter Building,
Office EG-05, P.O Box-342009, Dubai, UAE
Tel. +9714 3208499 - info@clivet.ae

Clivet South East Europe

Jarušiča 9b
10000, Zagreb, Croatia
Tel. +3851 222 8784 - info.see@clivet.com

CLIVET France

10, rue du Fort de Saint Cyr - 78180 Montigny le
Bretonneux, France
info.fr@clivet.com

Clivet Airconditioning Systems Pvt Ltd

Office No.501 & 502,5th Floor, Commercial -I,
Kohinoor City, Old Premier Compound, Off LBS
Marg, Kiroli Road, Kurla West, Mumbai
Maharashtra 400070, India
Tel. +91 22 30930200 - sales.india@clivet.com

SPINchiller4 - WSAT-YSC4 265.6 - 350.8 - BT23B006GB-01